

SOLJET PRO4

XF-640

USER'S MANUAL

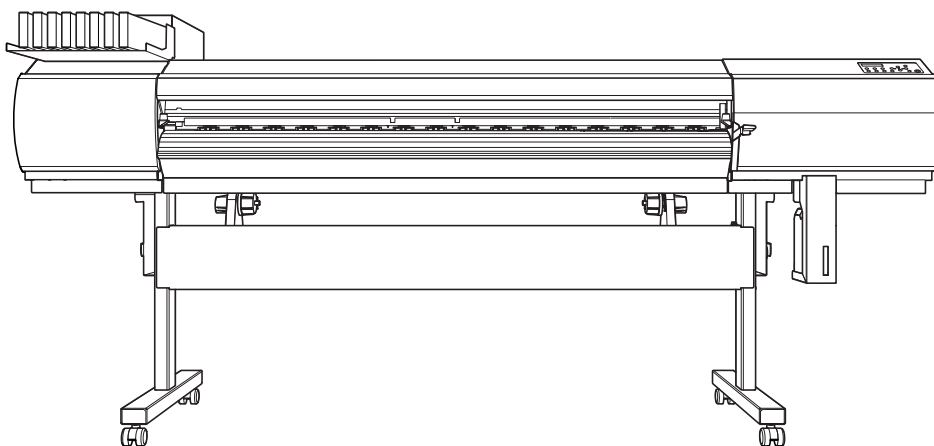

Thank you very much for purchasing this product.

- To ensure correct and safe usage with a full understanding of this product's performance, please be sure to read through this manual completely and store it in a safe location.
- Unauthorized copying or transferral, in whole or in part, of this manual is prohibited.
- The contents of this document and the specifications of this product are subject to change without notice.
- The documentation and the product have been prepared and tested as much as possible. If you find any misprint or error, please inform us.
- Roland DG Corp. assumes no responsibility for any direct or indirect loss or damage which may occur through use of this product, regardless of any failure to perform on the part of this product.
- Roland DG Corp. assumes no responsibility for any direct or indirect loss or damage which may occur with respect to any article made using this product.

Roland DG Corporation

This product is using GNU General Public License (GPL) / GNU Lesser General Public License (LGPL) software. You have the right to acquire, modify, and distribute the source code for this GPL/LGPL software. You can obtain the GPL/LGPL source code used in this product by downloading it from the following website.
URL: <http://www.rolanddg.com/gpl/>

RolandDG Corp. has licensed the MMP technology from the TPL Group.

For the USA

FEDERAL COMMUNICATIONS COMMISSION RADIO FREQUENCY INTERFERENCE STATEMENT

NOTE: This equipment has been tested and found to comply with the limits for a Class A digital device, pursuant to Part 15 of the FCC Rules.

These limits are designed to provide reasonable protection against harmful interference when the equipment is operated in a commercial environment.

This equipment generates, uses, and can radiate radio frequency energy and, if not installed and used in accordance with the instruction manual, may cause harmful interference to radio communications.

Operation of this equipment in a residential area is likely to cause harmful interference in which case the user will be required to correct the interference at his own expense.

Unauthorized changes or modification to this system can void the users authority to operate this equipment.

Use only I/O cables that have been designed and manufactured specifically for this device.

For Canada

NOTICE

This Class A digital apparatus meets all requirements of the Canadian Interference-Causing Equipment Regulations.

AVIS

Cet appareil numérique de la classe A respecte toutes les exigences du Règlement sur le matériel brouilleur du Canada.

For EU Countries

WARNING

This is a Class A product. In a domestic environment this product may cause radio interference in which case the user may be required to take adequate measures.

For California

WARNING

This product contains chemicals known to cause cancer, birth defects and other reproductive harm.



Manufacturer:

ROLAND DG CORPORATION

1-6-4 Shinmiyakoda, Kita-ku, Hamamatsu-shi, Shizuoka-ken, 431-2103 JAPAN

The authorized representative in the EU:

Roland DG EMEA, S.L.

Parc Tecnologic del Valles C/ Ceramistes, 6 08290 Cerdanyola del Valles / Barcelona Spain

NOTICE

Grounding Instructions

In the event of a malfunction or breakdown, grounding provides a path of least resistance for electric current to reduce the risk of electric shock. This tool is equipped with an electric cord having an equipment-grounding conductor and a grounding plug. The plug must be plugged into a matching outlet that is properly installed and grounded in accordance with all local codes and ordinances.

Do not modify the plug provided - if it will not fit the outlet, have the proper outlet installed by a qualified electrician.

Improper connection of the equipment-grounding conductor can result in a risk of electric shock. The conductor with insulation having an outer surface that is green with or without yellow stripes is the equipment-grounding conductor. If repair or replacement of the electric cord or plug is necessary, do not connect the equipment-grounding conductor to a live terminal.

Check with a qualified electrician or service personnel if the grounding instructions are not completely understood, or if in doubt as to whether the tool is properly grounded.

Use only 3-wire extension cords that have 3-prong grounding plugs and 3-pole receptacles that accept the tool's plug.

Repair or replace damaged or worn out cord immediately.

Operating Instructions

KEEP WORK AREA CLEAN. Cluttered areas and benches invites accidents.

DON'T USE IN DANGEROUS ENVIRONMENT. Don't use power tools in damp or wet locations, or expose them to rain. Keep work area well lighted.

DISCONNECT TOOLS before servicing; when changing accessories, such as blades, bits, cutters, and like.

REDUCE THE RISK OF UNINTENTIONAL STARTING. Make sure the switch is in off position before plugging in.

USE RECOMMENDED ACCESSORIES. Consult the owner's manual for recommended accessories. The use of improper accessories may cause risk of injury to persons.

NEVER LEAVE TOOL RUNNING UNATTENDED. **TURN POWER OFF.** Don't leave tool until it comes to a complete stop.

Contents

Contents	2
Chapter 1 Machine Highlights	5
Part Names and Functions.....	6
Printer Unit.....	6
Operation Panel	8
Menu List.....	9
Main Menu.....	9
Language and Unit Menu.....	12
Cleaning Menu	12
Heater Configuration Menu.....	12
⚠ To Ensure Safe Use.....	13
⚠ Pour utiliser en toute sécurité	20
Important Notes on Handling and Use	28
Chapter 2 Basic Operation.....	29
Prepare the Media.....	30
Type of Media	30
Conditions for Usable Media	30
Switch On!.....	31
Switch On!.....	31
The Power-saving Feature (Sleep Mode)	31
Loading Media.....	32
Loading Roll Media	32
Loading the Sheet Media	38
Performing the Initial Adjustment (Correcting for Misalignment in Bidirectional Printing More Precisely).....	42
Setup of Media	44
About [Media Setting] menu	44
Setup of Media ([Media Setting] menu).....	44
Outputting.....	50
Setting the Output-start Location.....	50
Printing Tests and Normal Cleaning	51
Getting Ready to Receive Data from a Computer	53
Starting Output.....	55
Pausing and Canceling Output	56
Cutting Off the Media	56
Switch Off	58
Switch Off.....	58
Chapter 3 Maintenance: For always using the printer in the best condition	59
Checking for Remaining Ink and Replacing Cartridges	60
Checking for Remaining Ink	60
How to Replace Ink Cartridges	61
Maintenance that Should Be Performed Daily	62
Disposing of Discharged Ink	62
Cleaning.....	64
About Care and Maintenance of The Print Heads	65
When Normal Cleaning Is Not Effective	66
Medium Cleaning.....	66
Powerful Cleaning.....	67

When Uneven Color Issue Occurs	68
Light Choke Cleaning.....	68
Maintenance that Should Be Performed More Than Once a Month	69
When Manual-Cleaning Becomes Necessary.....	69
Manual Cleaning.....	70
When Problems Such As Dot Drop-out are Not Cleared Up.....	76
When Problems Such As Dot Drop-out are Not Cleared Up.....	76
Replacing Consumable Parts.....	78
Replacing the Wipers	78
Replacing the Felt Wipers.....	81
Replacing the Separating Knife.....	84
When Not in Use for a Prolonged Period	86
Keep Performing Maintenance	86
Alarm Feature	86
Special maintenance.....	87
Draining Ink and Performing Internal Washing.....	87
Draining Ink Remaining Inside the Machine	87
Chapter 4 Part of Practice	89
Fully Utilizing Preset Function.....	90
Saving Various Settings as a Name Assigned Preset.....	90
Loading a Saved Preset	91
Automatic Loading of a Saved Preset When Media is Loaded.....	92
Fully Utilize the Media Heating System.....	93
What Is the Media Heating System?	93
Making the Temperature Setting for the Media Heating System	94
Control of Media Heating System during Preheating.....	95
Drying the Trailing Edge of the Printing Area on the Dryer.....	96
Setting the Drying Time after Printing.....	97
Using an Optional Dryer	97
Using a Blower-fan Unit	98
Fully Utilizing the Correction Function.....	99
Correcting for Misalignment in Bidirectional Printing.....	99
Correcting for Misalignment in Bidirectional Printing More Precisely.....	99
Alleviating Horizontal Bands (feed correction function)	100
Accommodating to the Types and Condition of Media	101
Adjusting the Print-Head Height to Match Media Thickness	101
Using Transparent Media.....	102
Printing Hard-to-dry Media	104
Using the Media Easy to be Winkled/Hard to be Fed	104
Speeding Up Output for Narrow Media.....	105
Expanding the Printing Area by Reducing the Margins.....	106
Preventing Soiling of the Media and Dot Drop-out.....	107
Using Sticky Media.....	108
Printing with Crop Marks	109
Printing with Crop Marks.....	109
Using Media Take-up System.....	110
Using Media Take-up System	110

Chapter 5 To Administrators.....	111
Output Operation Management.....	112
Printing a System Report.....	112
Determining What Happens When Ink Runs Out.....	112
Displaying the Amount of Media Remaining.....	113
Making Sure to Verify the Setting for the Amount Remaining Every Time the Media Is Changed...	114
Printing the Amount of Remaining Media.....	115
System Management of Printer.....	116
Setting for the Menu Language and the Units of Measurement.....	116
Setting the Interval until Activation of the Sleep Mode (Power Saving Function).....	116
Viewing Information about the System of This Machine.....	117
Returning All Settings to Their Initial Values.....	118
Chapter 6 Read This Chapter Whenever You Face a Problem. (FAQ)	119
Printer Does Not Start Up!	120
The Printer Unit Doesn't Run.....	120
The Media Heating System Doesn't Warm Up.....	121
Cannot Cut Off The Media.....	122
Attractive Printing is Impossible	123
Printed Results Are Coarse or Contain Horizontal Stripes	123
Colors Are Unstable or Uneven	124
The Media Becomes Soiled When Printed.....	125
Media Jam Occurs!	126
The Media Jams.....	126
Media Feed is Not Smooth.....	127
Media Wrinkles or Shrinks	127
Media Feed Is Not Straight.....	128
Media Feed Is Not Smooth.....	128
Print Heads Stop Moving. Why?	129
What to Do First	129
If the Print Heads Still Do Not Move	129
A Message Appears	131
An Error Message Appears	133
Chapter 7 Main Specifications.....	137
Printing Area.....	138
Maximum Area and Margins.....	138
Maximum Area When Using Crop Marks.....	139
The Media-cutoff Location During Continuous Printing	139
Locations of the Power Rating and Serial Number Labels.....	140
Specifications	141

Company names and product names are trademarks or registered trademarks of their respective holders.

Chapter 1

Machine Highlights

Part Names and Functions	6
Printer Unit.....	6
Operation Panel.....	8
Menu List	9
Main Menu.....	9
Language and Unit Menu	12
Cleaning Menu	12
Heater Configuration Menu	12
⚠ To Ensure Safe Use.....	13
⚠ Pour utiliser en toute sécurité	20
Important Notes on Handling and Use.....	28

Part Names and Functions

Printer Unit

Front

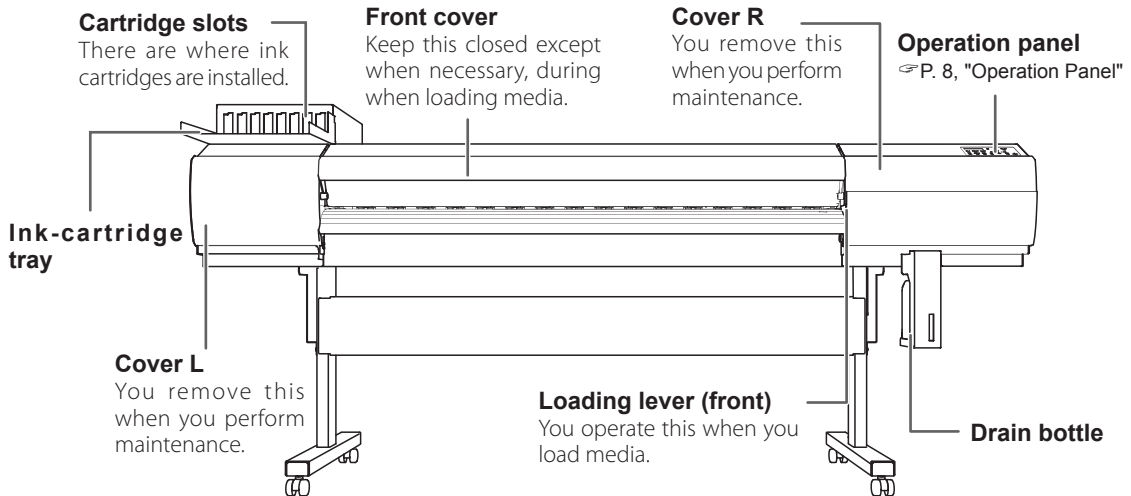

Rear

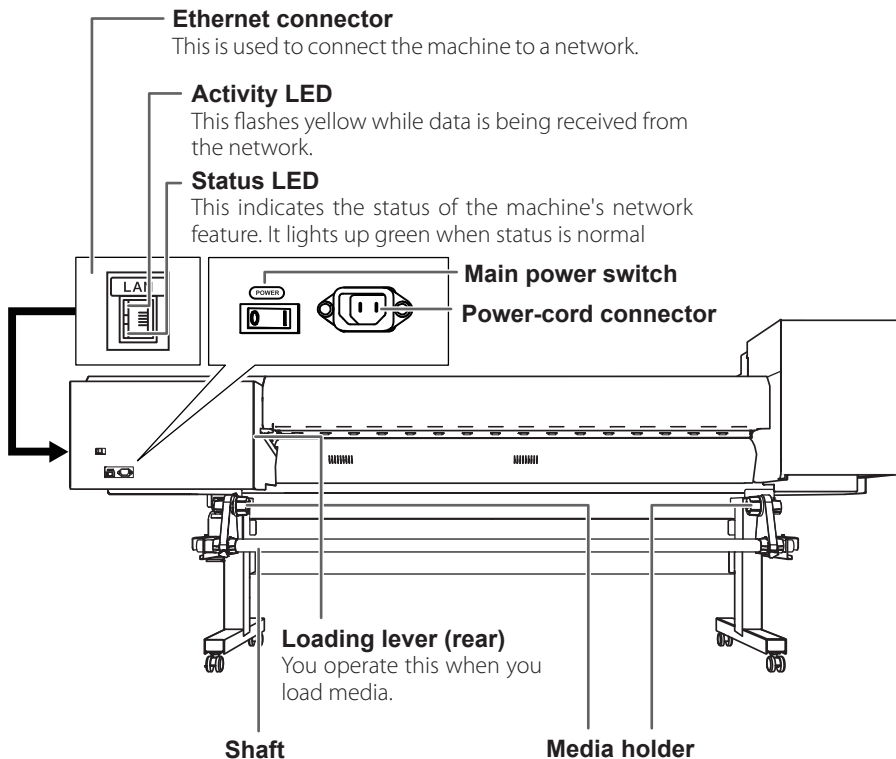

Front Cover Inside/Print Head Periphery

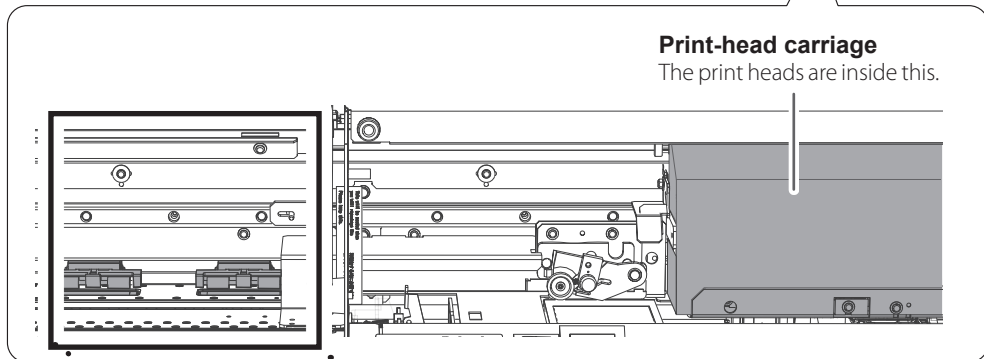
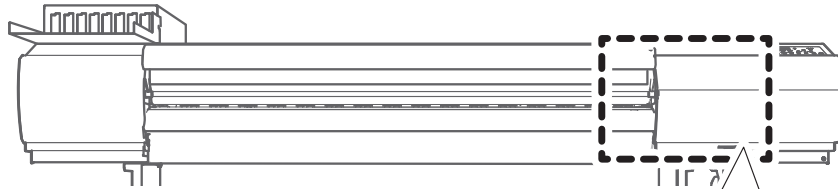

Pinch rollers

These clamp the media when the loading lever is pulled down.

Grit rollers

These rollers feed out media toward the front of the machine.

Knife guide

The separating knife passes through this when you perform media cutoff.

Platen

This is the path over which the media passes. A suction fan that keeps the media from coming loose and print heater that helps fix the ink are built in.

Apron

This has a built-in dryer to speed up drying of the ink.

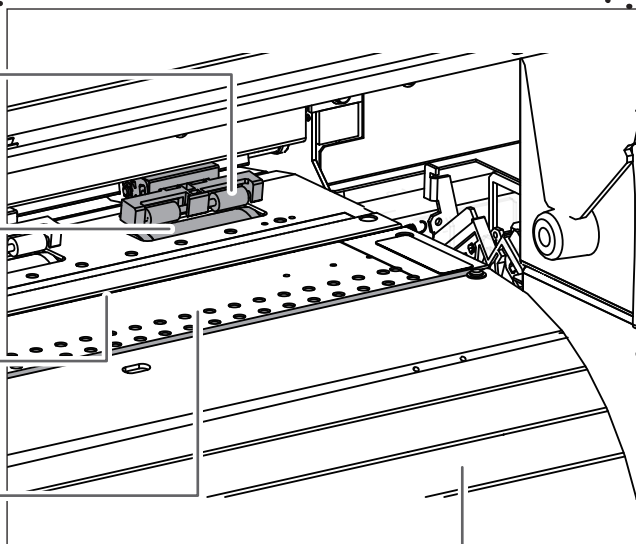

Operation Panel

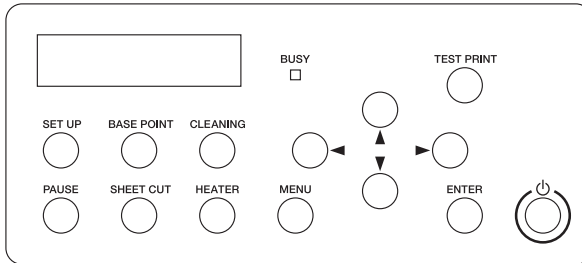

Parts	Name	Description	Illustration in this manual
	Display screen	This displays various setting menus and other information.	
	Sub power switch	This switches the printer on and off. (To switch the printer off, you hold down the switch for one second or longer). The light flashes slowly when the machine is in the sleep mode.	
	ENTER key	You use this for such tasks as enabling setting values.	
	MENU key	You press this to enter the menus for various settings.	
	HEATER key	You press this to make the temperature setting for the media heating system. This flashes during warm-up, then remains steadily lighted when the preset temperature is reached.	
	SHEET CUT key	Holding this down for one second or longer cuts off media.	
	PAUSE key	This pauses printing operation. This lights up when operation is paused.	
	SETUP key	You press this when you load media. This lights up when media is loaded and the machine is ready to perform output.	
	BASE POINT key	You use this when you want to set the outputstart location. This lights up when the setting has been made.	
	CLEANING key	You use this to perform cleaning of the print heads.	
	Cursor keys	You use these to select settings for menu items, to move the media, and for other such operations.	
	TEST PRINT key	Holding this down for one second or longer performs a printing test.	
	BUSY light	This lights up during printing, and other such operations.	

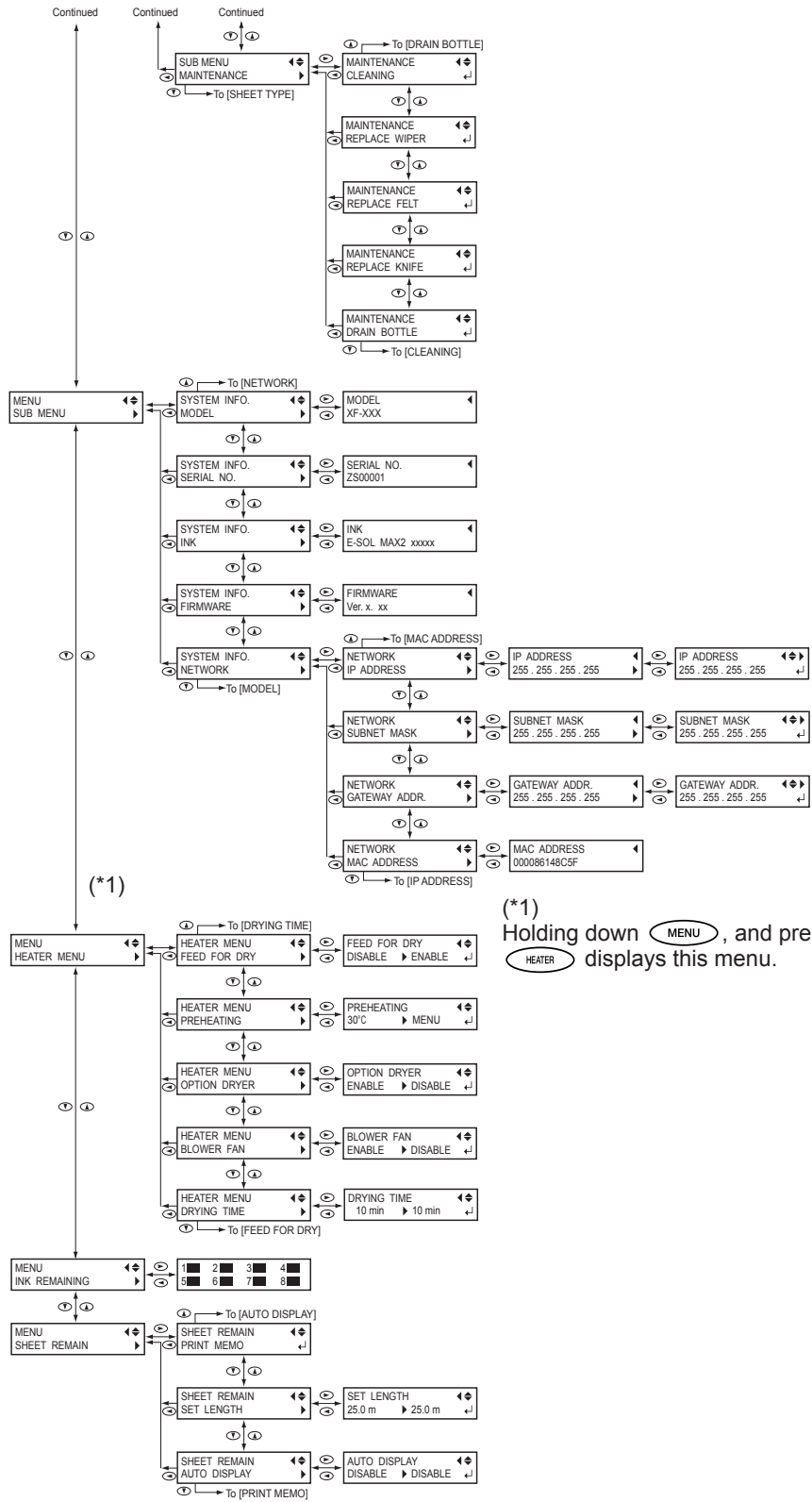

(*1)

(*1) Holding down **MENU**, and pressing **HEATER** displays this menu.

Language and Unit Menu

Hold down **MENU** and switch on the sub power.

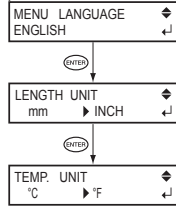

Cleaning Menu

Press **CLEANING**.

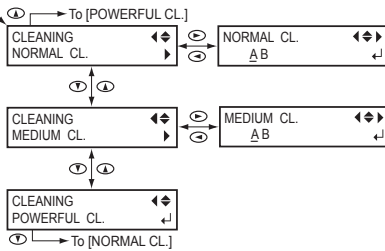

Hold down **CLEANING** for one second or longer.

Head cleaning for all groups

☞ P. 53, "When You Want to Clean All Print Heads Simultaneously"

Heater Configuration Menu

Press **HEATER**

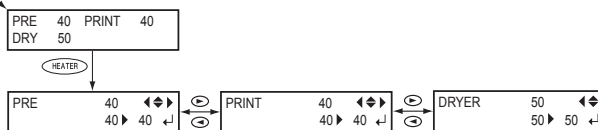







To Ensure Safe Use

Improper handling or operation of this machine may result in injury or damage to property. Points which must be observed to prevent such injury or damage are described as follows.

About ⚠️WARNING and ⚠️CAUTION Notices

 WARNING	Used for instructions intended to alert the user to the risk of death or severe injury should the unit be used improperly.
 CAUTION	Used for instructions intended to alert the user to the risk of injury or material damage should the unit be used improperly. Note: Material damage refers to damage or other adverse effects caused with respect to the home and all its furnishings, as well to domestic animals or pets.

About the Symbols

	The ⚠️ symbol alerts the user to important instructions or warnings. The specific meaning of the symbol is determined by the design contained within the triangle. The symbol at left means "danger of electrocution."
	The ⚡ symbol alerts the user to items that must never be carried out (are forbidden). The specific thing that must not be done is indicated by the design contained within the circle. The symbol at left means the unit must never be disassembled.
	The ● symbol alerts the user to things that must be carried out. The specific thing that must be done is indicated by the design contained within the circle. The symbol at left means the power-cord plug must be unplugged from the outlet.

 **Incorrect operation may cause injury**

 **WARNING**

 **Be sure to follow the operation procedures described in this documentation. Never allow anyone unfamiliar with the usage or handling of the machine to touch it.**
Incorrect usage or handling may lead to an accident.

 **Keep children away from the machine.**
The machine includes areas and components that pose a hazard to children and may result in injury, blindness, choking, or other serious accident.

 **Never operate the machine while tired or after ingesting alcohol or any medication.**
Operation requires unimpaired judgment. Impaired judgment may result in an accident.

 **Never use the machine for any purpose for which it is not intended, or use the machine in an undue manner that exceeds its capacity.**
Doing so may result in injury or fire.

 **For accessories (optional and consumable items, power cord, and the like), use only genuine articles compatible with this machine.**
Incompatible items may lead to an accident.

 **Before attempting cleaning, maintenance, or attachment or detachment of optional items, disconnect the power cord.**
Attempting such operations while the machine is connected to a power source may result in injury or electrical shock.

 **WARNING**

 **Never attempt to disassemble, repair, or modify the machine.**
Doing so may result in fire, electrical shock, or injury. Entrust repairs to a trained service technician.

 **CAUTION**

 **Exercise caution to avoid being pinched or becoming caught.**
Inadvertent contact with certain areas may cause the hand or fingers to be pinched or become caught. Use care when performing operations.

 **Never attempt operation while wearing a necktie, necklace, or loose clothing. Bind long hair securely.**
Such items may become caught in the machine, resulting in injury.

 **Conduct operations in a clean, brightly lit location.**
Working in a location that is dark or cluttered may lead to an accident, such as becoming caught in the machine as the result of an inadvertent stumble.

 **Never climb or lean on the machine.**
The machine is not made to support a person. Climbing or leaning on the machine may dislodge components and cause a slip or fall, resulting in injury.

 **Caution: cutting tool.**
This machine has an internal tool. To avoid injury, handle the tool with care.

⚠ Danger of electrical short, shock, electrocution, or fire

⚠ WARNING

! Connect to an electrical outlet that complies with this machine's ratings (for voltage, frequency, and current).
Incorrect voltage or insufficient current may cause fire or electrical shock.

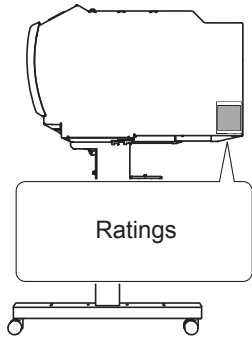

⊘ Never use out of doors or in any location where exposure to water or high humidity may occur. Never touch with wet hands.
Doing so may result in fire or electrical shock.

⊘ Never allow any foreign object to get inside. Never expose to liquid spills.
Inserting objects such as coins or matches or allowing beverages to be spilled into the ventilation ports may result in fire or electrical shock. If anything gets inside, immediately disconnect the power cord and contact your authorized Roland DG Corp. dealer.

⊘ Never place any flammable object nearby. Never use a combustible aerosol spray nearby. Never use in any location where gases can accumulate.
Combustion or explosion may be a danger.

⚠ WARNING

! Handle the power cord, plug, and electrical outlet correctly and with care. Never use any article that is damaged.
Using a damaged article may result in fire or electrical shock.

! When using an extension cord or power strip, use one that adequately satisfies the machine's ratings (for voltage, frequency, and current).
Use of multiple electrical loads on a single electrical outlet or of a lengthy extension cord may cause fire.

⏚ Connect to ground.
This can prevent fire or electrical shock due to current leakage in the event of malfunction.

! Position so that the power plug is within immediate reach at all times.
This is to enable quick disconnection of the power plug in the event of an emergency. Install the machine next to an electrical outlet. Also, provide enough empty space to allow immediate access to the electrical outlet.

! If sparking, smoke, burning odor, unusual sound, or abnormal operation occurs, immediately unplug the power cord. Never use if any component is damaged.
Continuing to use the machine may result in fire, electrical shock, or injury. Contact your authorized Roland DG Corp. dealer.

! Do not use the supplied power supply cord for other products.

 Important Notes About The Power Cord, Plug, and Electrical Outlet

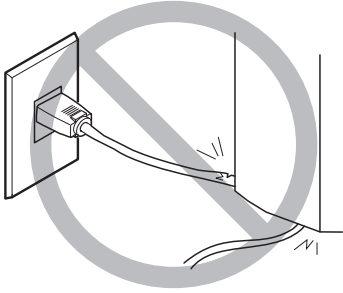

Never place any object on top or subject to damage.

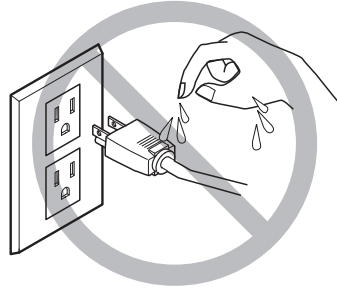

Never allow to get wet.

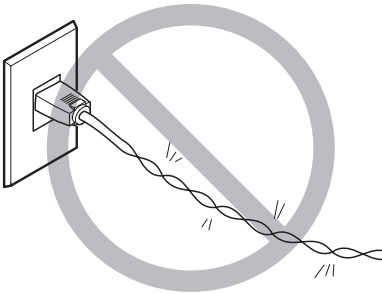

Never bend or twist with undue force.

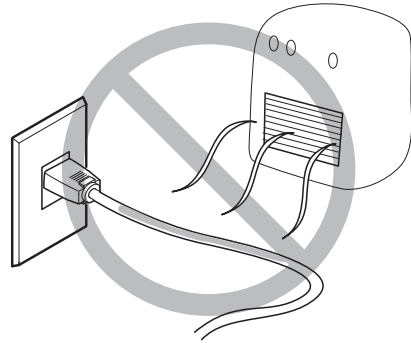

Never make hot.

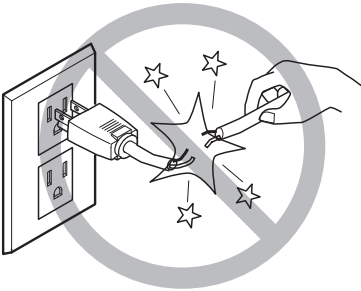

Never pull with undue force.

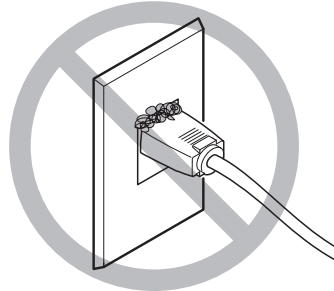

Dust may cause fire.

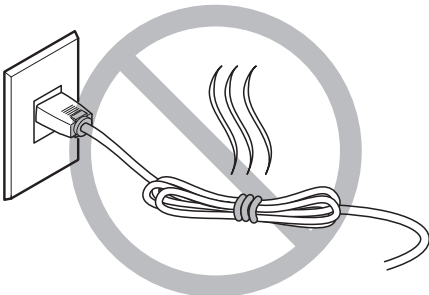

Never bundle, bind, or roll up.

 **Ink, cleaning liquid, and discharged fluid are flammable and toxic**

 **WARNING**

 **Keep open flame away from the work area.**
Ink and discharged fluid are flammable.

 **Never store ink, cleaning liquid, or discharged fluid in any of the following locations.**

- Any location exposed to open flame
- Any location where high temperature may occur
- Near bleach or any other such oxidizing agent or explosive material
- Any location within the reach of children

Fire may be a danger. Accidental ingestion by children may pose a health hazard.

 **Never place an ink cartridge in fire.**
Ink may flow out, catch fire, and spread fire to other nearby objects.

 **Never drink or sniff ink, cleaning liquid, or discharged fluid, or allow them to come in contact with the eyes or skin.**
Doing so may be hazardous to the health.

 **CAUTION**

 **Ensure adequate ventilation for the work area.**
Failing to perform ventilation may result in a health hazard or danger of combustion due to ink fumes.

 **Never allow an ink cartridge to be subjected to impact, and never attempt to disassemble.**
Ink may leak.

 **In The Event of Ingestion or Physical Distress**

- In the event of contact with the eyes, immediately flush with water for at least 15 minutes. If eye irritation continues, seek treatment by a physician.
- In the event of contact with skin, immediately wash with soap. If irritation or inflammation occurs, seek treatment by a physician.
- In the event of ingestion, do not induce vomiting, and immediately seek treatment by a physician. Forcibly inducing vomiting may lead to danger of choking.
- If odor leads to physical distress, move to a well-ventilated location and rest quietly. If dizziness or nausea persists, seek treatment by a physician.

 **The total maximum weight of this machine reaches 300 kg (661 lb.).
Media weighs 40 kg (88 lb.).**

 **WARNING**

 **Install the machine in a location that is level, stable, and able to bear the weight of the machine.**

The total maximum weight of this machine reaches 300 kg (661 lb.). Installation in an unsuitable location may cause a major accident, including tip over, fall, or collapse.

 **Unloading and emplacement are operations that must be performed by 6 persons or more.**

Tasks that require undue effort when performed by a small number of persons may result in physical injury. Also, if dropped, such items may cause injury.

 **WARNING**

 **Be sure to lock the stand's casters.**
If the machine should begin to topple, a major accident may result, including crushing of the appendages or the body.

 **When storing roll media, implement adequate safety measures to ensure that the stored media will not roll, fall, or topple over.**

Danger exists of becoming pinned under the media and suffering serious injury.

 **Handling roll media is an operation that must be performed by two persons or more, and care must be taken to prevent falls.**

Attempting to lift heavy media in a manner that taxes your strength may cause physical injury.

 **Danger of fire, burns, or toxic gas emissions**

 **WARNING**

 **Caution: high temperatures**
Areas such as the dryer become hot. Exercise caution to avoid fire or burns.

 **When printing is not being performed, remove any loaded media or switch off the power.**

The continued application of heat at a single location may cause the release of toxic gases from the media or pose a fire hazard.

 **WARNING**

 **Never use media that cannot withstand heat.**
Doing so may degrade the media, or may result in fire or the release of toxic gases.

⚠ Warning Labels

Warning labels are affixed to make areas of danger immediately clear. The meanings of these labels are as follows. Be sure to heed their warnings. Also, never remove the labels or allow them to become obscured.



Ink Is Toxic
Ink and discharged fluid are toxic. Avoid contact with the body. Use only in a well-ventilated area.



Flammable
Ink and discharged fluid are flammable. Keep away from open flame.



Caution: Moving Print Heads
The print heads inside the cover move at high speed and pose a hazard. Never insert the hand or fingers into the gap.



Caution: Pinching Hazard
Be careful not to allow the fingers to become pinched when closing covers.

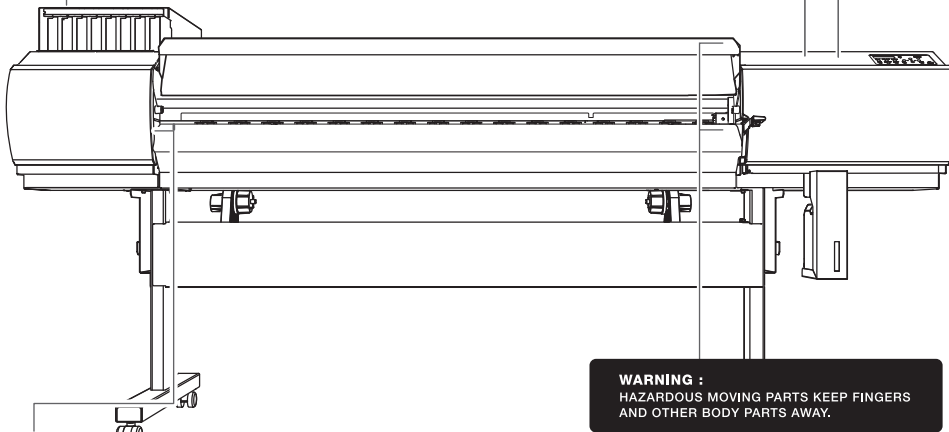

Caution: High Temperature
The platen and dryer become hot. Exercise caution to avoid fire or burns.

WARNING :
HAZARDOUS MOVING PARTS KEEP FINGERS AND OTHER BODY PARTS AWAY.

Caution: Moving Print Heads
The print heads inside the front cover move at high speed and pose a hazard. Never insert the hand or fingers into the gap.



Caution: High Voltage
Cover removal may pose hazard of shock or electrocution due to high voltage.

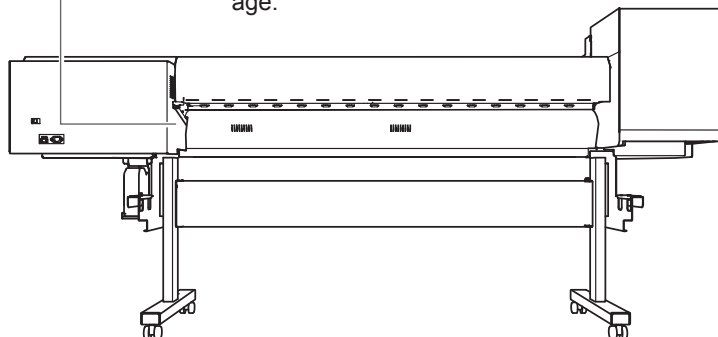











Pour utiliser en toute sécurité

La manipulation ou l'utilisation inadéquates de cet appareil peuvent causer des blessures ou des dommages matériels. Les précautions à prendre pour prévenir les blessures ou les dommages sont décrites ci-dessous.

Avis sur les avertissements

 ATTENTION	Utilisé pour avertir l'utilisateur d'un risque de décès ou de blessure grave en cas de mauvaise utilisation de l'appareil.
 PRUDENCE	Utilisé pour avertir l'utilisateur d'un risque de blessure ou de dommage matériel en cas de mauvaise utilisation de l'appareil. * Par dommage matériel, il est entendu dommage ou tout autre effet indésirable sur la maison, tous les meubles et même les animaux domestiques.

À propos des symboles

	Le symbole  attire l'attention de l'utilisateur sur les instructions importantes ou les avertissements. Le sens précis du symbole est déterminé par le dessin à l'intérieur du triangle. Le symbole à gauche signifie "danger d'électrocution."
	Le symbole  avertit l'utilisateur de ce qu'il ne doit pas faire, ce qui est interdit. La chose spécifique à ne pas faire est indiquée par le dessin à l'intérieur du cercle. Le symbole à gauche signifie que l'appareil ne doit jamais être démonté.
	Le symbole  prévient l'utilisateur sur ce qu'il doit faire. La chose spécifique à faire est indiquée par le dessin à l'intérieur du cercle. Le symbole à gauche signifie que le fil électrique doit être débranché de la prise.

 **L'utilisation incorrecte peut causer des blessures**

 **ATTENTION**

 **S'assurer de suivre les procédures d'utilisation décrites dans la documentation. Ne jamais permettre à quiconque ne connaît pas le fonctionnement ou la manutention de l'appareil de le toucher.**
L'utilisation ou la manutention incorrectes peuvent causer un accident.

 **Garder les enfants loin de l'appareil.**
L'appareil comporte des zones et des composants qui présentent un danger pour les enfants et qui pourraient causer des blessures, la cécité, la suffocation ou d'autres accidents graves.

 **Ne jamais faire fonctionner l'appareil après avoir consommé de l'alcool ou des médicaments, ou dans un état de fatigue.**
L'utilisation de l'appareil exige un jugement sans faille. L'utilisation avec les facultés affaiblies pourrait entraîner un accident.

 **Ne jamais utiliser l'appareil à des fins autres que celles pour lesquelles il est conçu. Ne jamais l'utiliser de manière abusive ou d'une manière qui dépasse sa capacité.**
Le non-respect de cette consigne peut causer des blessures ou un incendie.

 **Utiliser uniquement des accessoires d'origine (accessoires en option, articles consommables, câble d'alimentation et autres articles semblables), compatibles avec l'appareil.**
Les articles incompatibles risquent de causer des accidents.

 **ATTENTION**

 **Débrancher le câble d'alimentation avant de procéder au nettoyage ou à l'entretien de l'appareil, et avant d'y fixer ou d'en retirer des accessoires en option.**
Tenter ces opérations pendant que l'appareil est branché à une source d'alimentation peut causer des blessures ou un choc électrique.

 **Ne jamais tenter de démonter, de réparer ou de modifier l'appareil.**
Le non-respect de cette consigne risque de provoquer un incendie, un choc électrique ou des blessures. Confier les réparations à un technicien ayant la formation requise.

 **PRUDENCE**

 **Faire preuve de prudence pour éviter l'écrasement ou le coincement.**
La main ou les doigts peuvent être écrasés ou coincés s'ils entrent en contact avec certaines surfaces par inadvertance. Faire preuve de prudence pendant l'utilisation de l'appareil.

 **Ne jamais faire fonctionner l'appareil si on porte une cravate, un collier ou des vêtements amples. Bien attacher les cheveux longs.**
Ces vêtements ou ces objets peuvent être coincés dans l'appareil, ce qui causerait des blessures.

⚠ PRUDENCE



Utiliser l'appareil dans un endroit propre et bien éclairé.

Travailler dans un endroit sombre ou encombré peut causer un accident; l'utilisateur risque, par exemple, de trébucher malencontreusement et d'être coincé par une partie de l'appareil.

⚠ PRUDENCE



Ne jamais grimper ni s'appuyer sur la machine.

La machine n'est pas conçue pour supporter le poids d'une personne. Grimper ou s'appuyer sur la machine peut déplacer des éléments et causer un faux pas ou une chute, ce qui causerait des blessures.



Attention : outil de coupe.

Cet appareil contient un outil interne. Pour éviter les blessures, manipuler l'outil avec soin.

⚠ **Risque de décharge ou de choc électrique, d'électrocution ou d'incendie**

⚠ ATTENTION



Brancher à une prise électrique conforme aux caractéristiques de cet appareil (tension, fréquence et courant).

Une tension incorrecte ou un courant insuffisant peuvent causer un incendie ou un choc électrique.

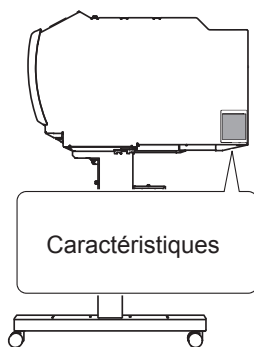

⚠ ATTENTION



Ne jamais utiliser à l'extérieur ni à un endroit où l'appareil risque d'être exposé à de l'eau ou à une humidité élevée. Ne jamais toucher l'appareil avec des mains mouillées.

Le non-respect de cette consigne risque de provoquer un incendie ou un choc électrique.



Ne jamais insérer d'objet étranger dans l'appareil. Ne jamais exposer l'appareil aux déversements de liquides.

L'insertion d'objets comme des pièces de monnaie ou des allumettes, ou le déversement de liquides dans les orifices de ventilation peuvent causer un incendie ou un choc électrique. Si un objet ou du liquide s'infiltré dans l'appareil, débrancher immédiatement le câble d'alimentation et communiquer avec le représentant Roland DG Corp. autorisé.

ATTENTION



Ne jamais placer d'objet inflammable à proximité de l'appareil. Ne jamais utiliser de produit inflammable en aérosol à proximité de l'appareil. Ne jamais utiliser l'appareil dans un endroit où des gaz peuvent s'accumuler.

Une combustion ou une explosion pourraient se produire.



Manipuler le câble d'alimentation, la fiche et la prise électrique correctement et avec soin.

Ne jamais utiliser un article endommagé, car cela pourrait causer un incendie ou un choc électrique.



Si une rallonge ou une bande d'alimentation électrique sont utilisées, s'assurer qu'elles correspondent aux caractéristiques de l'appareil (tension, fréquence et courant).

L'utilisation de plusieurs charges électriques sur une prise unique ou une longue rallonge peut causer un incendie.



Mise à la terre.

La mise à la terre peut prévenir un incendie ou un choc électrique dus à une fuite de courant en cas de défaillance.



Placer l'appareil de façon à ce que la fiche soit facile d'accès en tout temps.

Ainsi, l'appareil pourra être débranché rapidement en cas d'urgence. Installer l'appareil près d'une prise électrique. En outre, prévoir suffisamment d'espace pour que la prise électrique soit facile d'accès.

ATTENTION



S'il se produit des étincelles, de la fumée, une odeur de brûlé, un bruit inhabituel ou un fonctionnement anormal, débrancher immédiatement le câble d'alimentation. Ne jamais utiliser si un composant est endommagé.

Continuer à utiliser l'appareil peut causer un incendie, un choc électrique ou des blessures. Communiquer avec le représentant Roland DG Corp. Autorisé.



Ne pas utiliser le cordon électrique fourni avec d'autres produits.

⚠ Remarques importantes à propos du câble d'alimentation, de la fiche et de la prise électrique

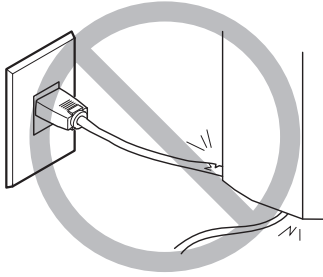

Ne jamais déposer aucun objet sur le câble, sur la fiche ou sur la prise car cela risque de les endommager.

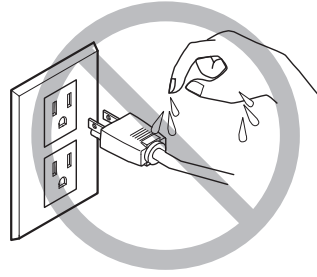

Ne jamais laisser l'eau toucher le câble, la fiche ou la prise.

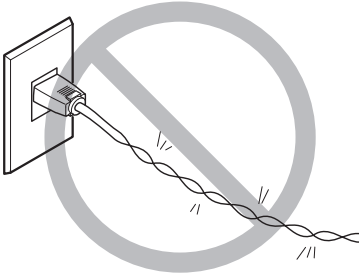

Ne jamais plier ni tordre le câble avec une force excessive.

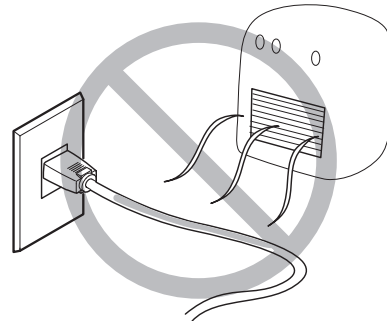

Ne jamais chauffer le câble, la fiche ou la prise.

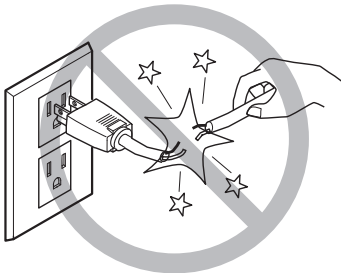

Ne jamais tirer sur le câble ou la fiche avec une force excessive.

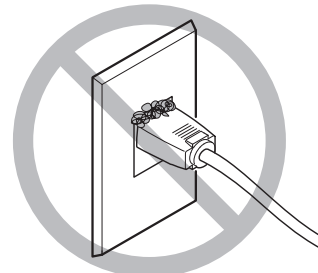

La poussière peut causer un incendie.

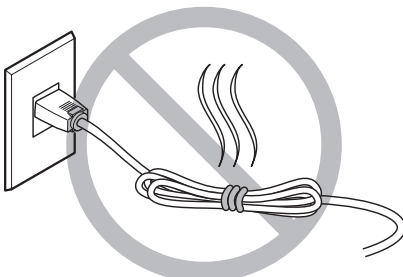

Ne jamais plier ni enrouler le câble.

 **L'encre, les liquides nettoyants et les liquides usés sont inflammables et toxiques**

 **ATTENTION**



Ne pas approcher une flamme nue de l'espace de travail.

L'encre et les liquides usés sont inflammables.



Ne jamais entreposer d'encre, de liquide de nettoyage ou des liquides usés dans les endroits suivants :

- un endroit exposé à une flamme nue;
- un endroit où il y a risque de température élevée;
- près d'eau de Javel, d'un autre agent d'oxydation ou de matériel explosif;
- tout endroit à la portée d'enfants.

Il y a risque d'incendie. L'ingestion accidentelle par un enfant peut présenter un risque pour la santé.



Ne jamais incinérer une cartouche d'encre.

De l'encre pourrait couler, s'enflammer et le feu se répandre à des objets proches.

 **ATTENTION**



Ne jamais boire l'encre, le liquide de nettoyage ni les liquides usés, ne pas en respirer les vapeurs et ne pas laisser les produits entrer en contact avec les yeux ou la peau.

Cela est dangereux pour la santé.



 **PRUDENCE**



S'assurer que le lieu de travail est bien aéré.

L'absence d'aération adéquate peut créer une situation dangereuse pour la santé ou un risque de combustion à cause des vapeurs qui émanent de l'encre.



Ne jamais soumettre une cartouche d'encre à des chocs. Ne jamais tenter d'ouvrir une cartouche d'encre.

De l'encre pourrait s'échapper.

 **En cas d'ingestion ou de trouble physique**

- **En cas de contact avec les yeux : rincer immédiatement et abondamment à l'eau courante pendant au moins 15 minutes. Si les yeux sont toujours irrités, consulter un médecin.**
- **En cas de contact avec la peau : laver immédiatement à l'eau et au savon. En cas d'irritation ou d'inflammation de la peau : consulter un médecin.**
- **En cas d'ingestion : ne pas provoquer le vomissement et demander immédiatement l'aide d'un médecin. Provoquer le vomissement peut créer un risque de suffocation.**
- **Si l'odeur cause un trouble physique, amener la personne dans un endroit bien aéré et la faire se reposer. Si l'étourdissement ou la nausée persistent, consulter un médecin.**

 **Le poids brut maximum de cette machine atteint 300 kg (661 lb.)
Le poids du support est de 40 kg (88 lb.)**

 **ATTENTION**

 **Installer l'appareil à un endroit stable et plat et capable de supporter son poids.**
Le poids brut maximum de cette machine atteint 300 kg (661 lb.). Installer l'appareil à un endroit inapproprié peut provoquer un accident grave comme le renversement, la chute ou l'écrasement.

 **Le déchargement et la mise en place doivent être faits par au moins 6 personnes ou plus.**
Les tâches qui exigent un effort trop grand si elles sont exécutées par un petit nombre de personnes peuvent être cause de blessures. La chute d'articles très lourds peut aussi causer des blessures.

 **ATTENTION**

 **S'assurer de verrouiller les roulettes de la base.**
Si l'appareil devait commencer à basculer, il s'ensuivrait un accident grave, par exemple l'écrasement de membres ou du corps.

 **Prendre les mesures de sécurité adéquates pour l'entreposage des rouleaux de support pour s'assurer qu'ils ne rouleront pas, ne tomberont pas et ne se renverseront pas.**
Il y a risque d'être écrasé par le support et de subir des blessures graves.

 **La manutention du support en rouleau doit être faite par deux personnes ou plus et il faut prendre des précautions pour éviter les chutes.**
Tenter de soulever des objets trop lourds peut causer des blessures.

 **Risque d'incendie, de brûlures ou d'émissions de gaz toxiques**

 **ATTENTION**

 **Attention : températures élevées.**
Les zones comme le séchoir chauffent. Faire preuve de prudence pour éviter un incendie ou des brûlures.

 **Quand aucun travail d'impression n'est en cours, retirer tout support de l'appareil ou couper l'alimentation électrique.**
L'application continue de chaleur à un point unique peut causer l'émission de gaz toxiques ou créer un risque d'incendie.

 **ATTENTION**

 **Ne jamais utiliser un support qui ne peut pas supporter la chaleur.**
L'utilisation d'un support qui ne supporte pas la chaleur peut détériorer le support, créer un risque d'incendie ou causer l'émission de gaz toxiques.

⚠ Vignettes d'avertissement

Des vignettes d'avertissement sont apposées pour qu'il soit facile de repérer les zones dangereuses. La signification des vignettes est donnée ci-dessous. Respecter les avertissements. Ne jamais retirer les vignettes et ne pas les laisser s'encrasser.



L'encre est toxique

L'encre et les liquides usés sont toxiques. Éviter tout contact avec le corps. Utiliser uniquement dans un endroit bien aéré.



Inflammable

L'encre et les liquides usés sont inflammables. Les garder loin de toute flamme nue.



Attention : Têtes d'impression mobiles

Les têtes d'impression sous le couvercle se déplacent à haute vitesse et représentent un danger. Ne jamais insérer la main ou les doigts dans l'ouverture.



Attention : Risque de pincement

Faire attention de ne pas coincer les doigts pendant le chargement du support ou lors de la fermeture du couvercle.

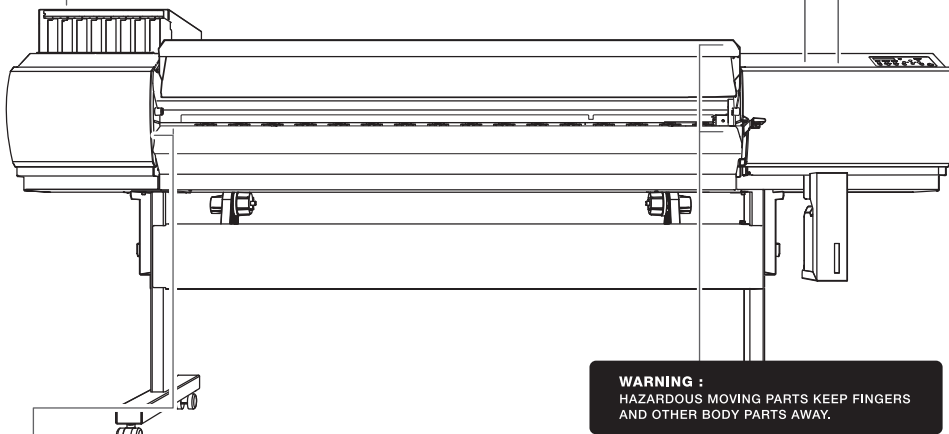

Attention : Température élevée

La platine et la surface de séchage chauffent. Être prudent pour éviter un incendie ou des brûlures.

WARNING :
HAZARDOUS MOVING PARTS KEEP FINGERS
AND OTHER BODY PARTS AWAY.

Attention : Têtes d'impression mobiles

N'insérez pas votre main au-dessous du couvercle avant. La tête d'impression se déplace à haute vitesse à l'intérieur du couvercle avant, ce qui est très dangereux.



Attention : voltage élevé

Il peut être dangereux de retirer le couvercle puisqu'il y aurait des risques de chocs électriques ou d'électrocution à cause du voltage élevé.

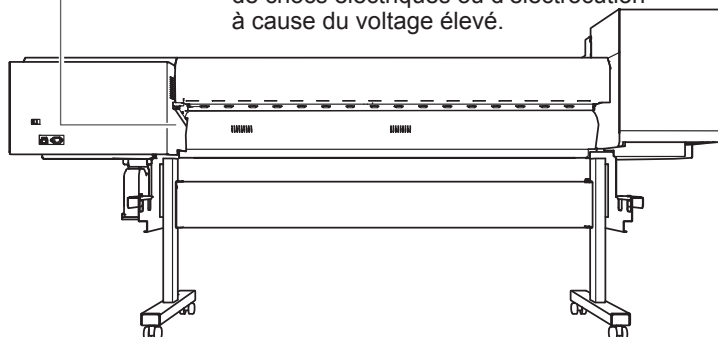

Important Notes on Handling and Use

This machine is a precision device. To ensure the full performance of this machine, be sure to observe the following important points. Failure to observe them may not only result in loss of performance, but may also cause malfunction or breakdown.

Printer Unit

This machine is a precision device.

- Handle carefully, and never subject the machine to impact or excessive force.
- Never needlessly put your hand or fingers inside the cover, the ink-cartridge ports, or other internal areas of the machine.

Install in a suitable location.

- Install in a location having the specified temperature and relative humidity.
- Install in a quiet, stable location offering good operating conditions.

The print heads are delicate.

- Never needlessly touch or allow media to scrape them. Failure to handle with care may cause damage.
- The print heads may be damaged if allowed to dry out. The machine prevents desiccation automatically, but improper operation may render this feature inoperative. Operate properly, as specified in this manual.
- Never allow the machine to stand with an ink cartridge removed. Remaining ink in the printer may harden and clog the print heads.
- The print heads are components that wear out. Periodic replacement is required, with the frequency of replacement depending on use.

This machine becomes hot.

- Never cover the ventilation holes with cloth, tape, or anything else.

Ink Cartridges

Ink cartridges come in various types.

- Use a type that is compatible with the printer. Also, be sure to use only genuine items from Roland DG Corp.

Never subject to impact or attempt to disassemble.

- Never drop or shake forcefully. The impact may rupture the internal pouch and cause the ink to leak.
- Never attempt to disassemble.
- Never attempt to refill the ink.
- If ink gets on your hands or clothing, wash it off as soon as possible. Removal may become difficult if allowed to stand.

Storage

- Store unopened in a well-ventilated location at a temperature of -20 to 40°C (-4 to 104°F).

Chapter 2

Basic Operation

Prepare the Media	30
Type of Media	30
Conditions for Usable Media	30
Switch On!.....	31
Switch On!	31
The Power-saving Feature (Sleep Mode).....	31
Loading Media	32
Loading Roll Media.....	32
Loading the Sheet Media.....	38
Performing the Initial Adjustment (Correcting for Misalignment in Bidirectional Printing More Precisely).....	42
Setup of Media.....	44
About [Media Setting] menu	44
Setup of Media ([Media Setting] menu).....	44
Outputting	50
Setting the Output-start Location.....	50
Printing Tests and Normal Cleaning	51
Getting Ready to Receive Data from a Computer.....	53
Starting Output	55
Pausing and Canceling Output.....	56
Cutting Off the Media.....	56
Switch Off.....	58
Switch Off	58

Prepare the Media

Type of Media

In this manual, the paper used for output is called "media." There are the following main two media types used in this machine.

- **Roll media : Media wound onto a paper tube**
- **Sheet media : Media not wound onto a paper tube such as standard-size media**

Various paper quality types of roll media and sheet media are selectable according your purpose. For detailed information about each media, contact your media supplier. Media is also available from our following website. <http://www.rolanddg.com/>

Conditions for Usable Media

This machine cannot necessarily print every kind of media. When selecting media, be sure to carry out testing in advance to make sure that satisfactory printing quality is obtained.

Size

Width (For both roll media and sheet media)

259 to 1,625 mm (10.2 to 64 inches)

Maximum media (including backing paper) thickness (For both roll media and sheet media)

1.0 mm (39 mil)

Roll outer diameter

210 mm (8.2 inches)

Paper tube (core) inner diameter

76.2 mm (3 inches) or 50.8 mm (2 inches)

Note: To use 2 inches media, the optional media flanges are required. For information about optional items, contact your authorized Roland DG Corp. dealer.

Roll Weight

40 kg (88 lb.)

Other Conditions

Media such as the following cannot be used.

- Media whose end is attached to the paper tube (core)
- Media which is severely wrapped or which has a strong tendency to reroll
- Media that cannot withstand the heat of the media heating system
- Media whose paper tube (core) is bent or crushed
- Media that bends under its own weight when loaded
- Media on a sagging roll
- Media that is rolled unevenly

Switch On!

Switch On!

WARNING

When output is not being performed, remove any loaded media or switch off the sub power.

The continued application of heat at a single location may cause the release of toxic gases from the media or pose a fire hazard.

Procedure

1

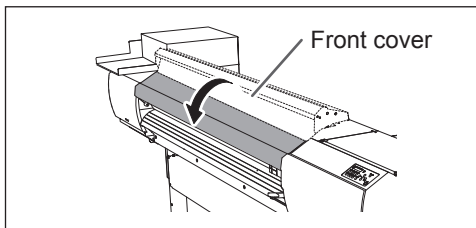

Close the front cover.

2

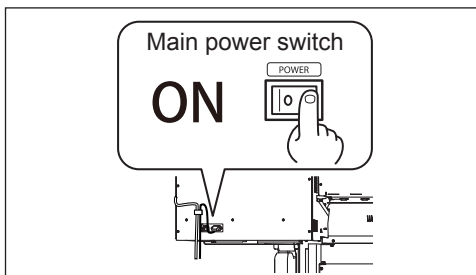

Turn on the main power switch.

3

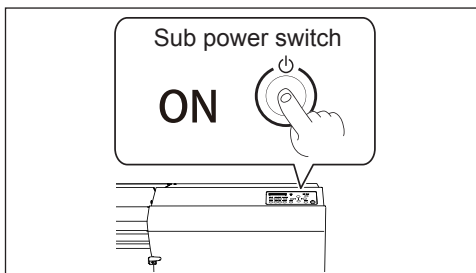

Press the sub power button.

Note: Method of installing ink cartridges, refer to "Setup Guide."

Note: Setting for the Menu Language and the Units of Measurement, refer to P. 116, "Setting for the Menu Language and the Units of Measurement"

The Power-saving Feature (Sleep Mode)

This machine is provided with a power-saving feature that switches to a low-power "sleep mode" when a fixed interval passes with no operation. The factory default for the time after which the machine switches to the sleep mode is 30 minutes. When the machine is in the sleep mode, the sub power switch flashes slowly. Using the operation panel or performing operations such as sending output data from the computer (when media is loaded) restores the machine to its normal mode.

This setting of sleep mode can be changed. However, we recommend setting the activation time for the sleep mode to 30 minutes or less to reduce power consumption and prevent problems such as overheating.

☞ P. 116, "Setting the Interval until Activation of the Sleep Mode (Power Saving Function)"

Loading Media

Loading Roll Media

⚠ CAUTION

Load roll media correctly.
Otherwise the media may fall and cause injury.

⚠ CAUTION

Roll media weighs about 40 kg (88 lb.). To avoid injury, handle with care.

⚠ CAUTION

Never load media that weighs over 40 kg (88 lb.).
The machine may fail to withstand the weight and tip over or cause the media to fall.

1. Install the media to the media holder.

Note: The media holder of this machine is exclusive use for the media of paper tube (core) inner diameter 3 inches. To use 2 inches media, the optional media flanges are required. For information about optional items, contact your authorized Roland DG Corp. dealer.

1 Open the front cover.

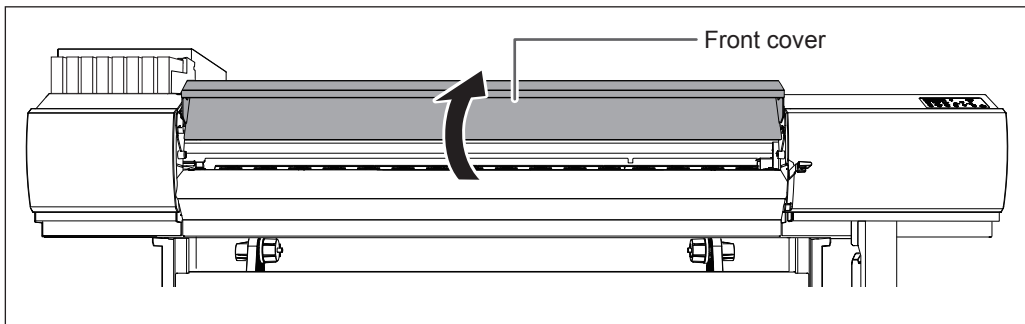

- 2 ① Loosen the retaining screws of the media holders and move the media holders to the left and right.
② Secure the media holder [Left] with the location shown in the figure.

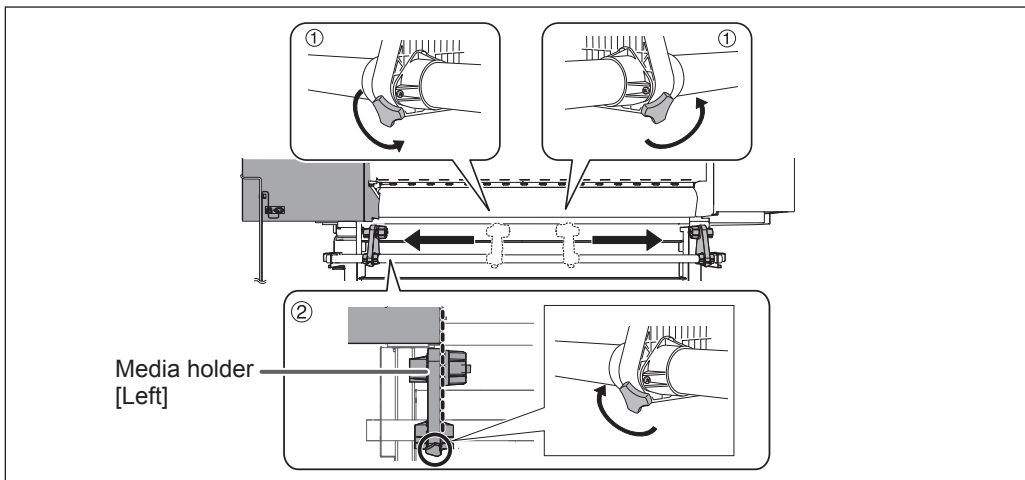

- 3 ① Fit the paper tube (core) onto the end cap of the media holder [Left].
- ② Move the media holder [Right] and fit the end cap onto the paper tube (core) of the media.

Fit it securely to prevent the media from easy loose.

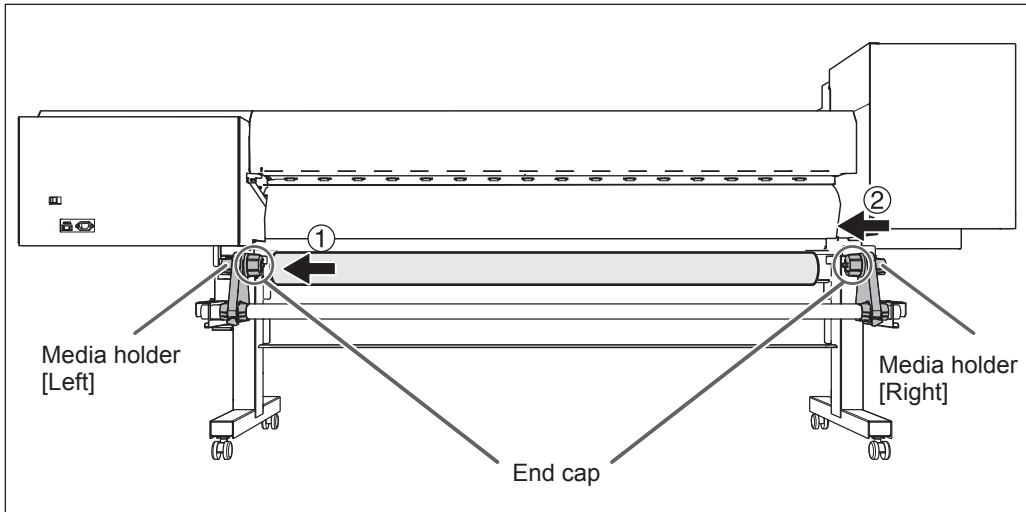

How to use the media flanges for the paper tube inner diameter 2 inches

* The media flanges for the paper tube inner diameter 2 inches are optional items.

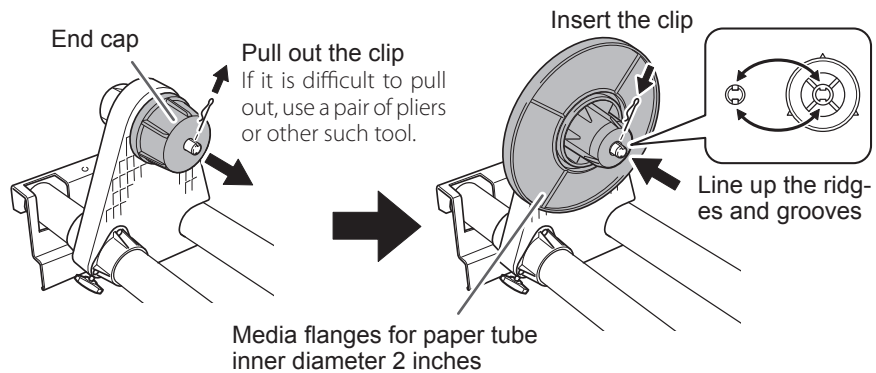

- 4
- ① Loosen the retaining screws of the media holder [Left].
 - ② Hold the outside of the media holder and align the left edge of the media with the mark.
- When deciding the position, hold the both sides of media holders from the outer sides and move it. Do not hold the media directly to move.

CAUTION Never attempt this operation while holding any location other than the one specified.
The media may fall from the media holder, resulting in injury.

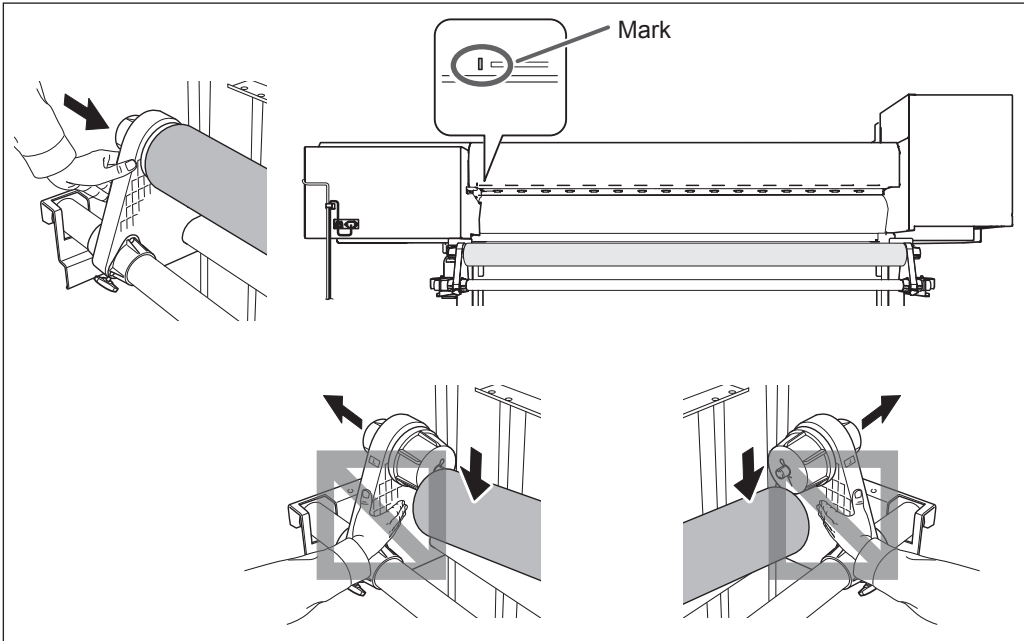

IMPORTANT! Decide the left and right side positions of the media finally at this step. After this procedure is completed, if the left and right side positions do not fit the proper position when securing the media with pinch rollers, go back to this step to redo this procedure. Printing quality is affected due to skew media feed, if you hold the media only to readjust the position forcibly.

- 5
- Secure the media holder by tightening the securing screws slightly.
- The retaining screw may get damaged if tightened excessively.

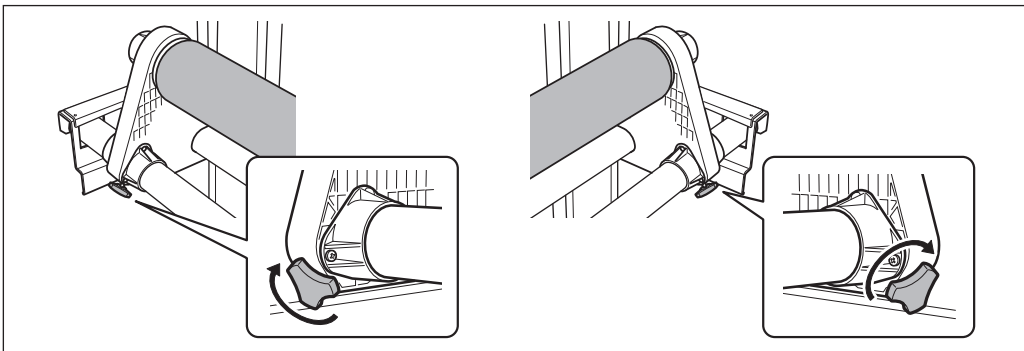

2. Pass the media through the printer and secure the media.

- 1 Pass the leading edge of the media between the pinch rollers and the grit rollers.

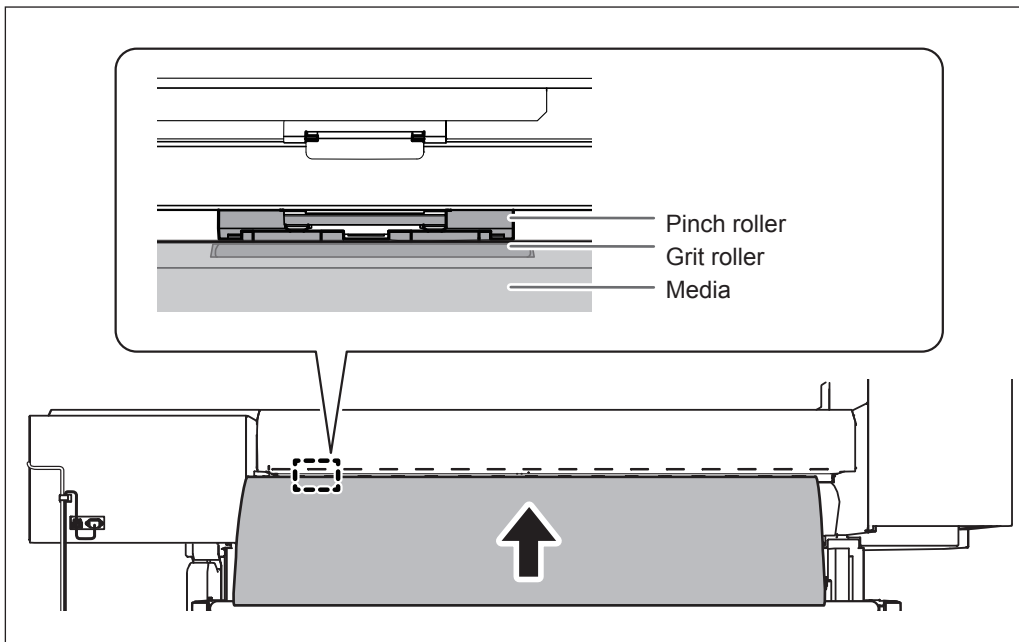

2

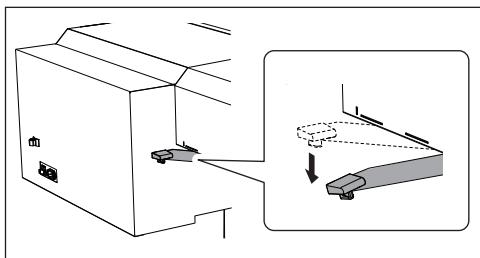

Down the loading lever (rear).

The media is held in place.

3

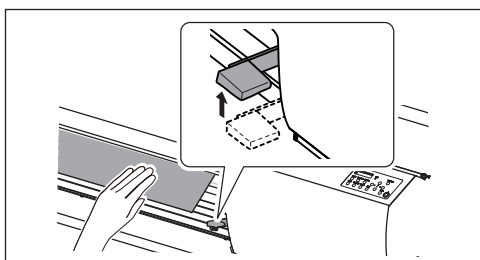

While lightly pressing down the media, raise the loading lever (front).

The media is released.

4 Pull out the media over the platen.

Confirm that the right edge of the media is aligned with the guideline.

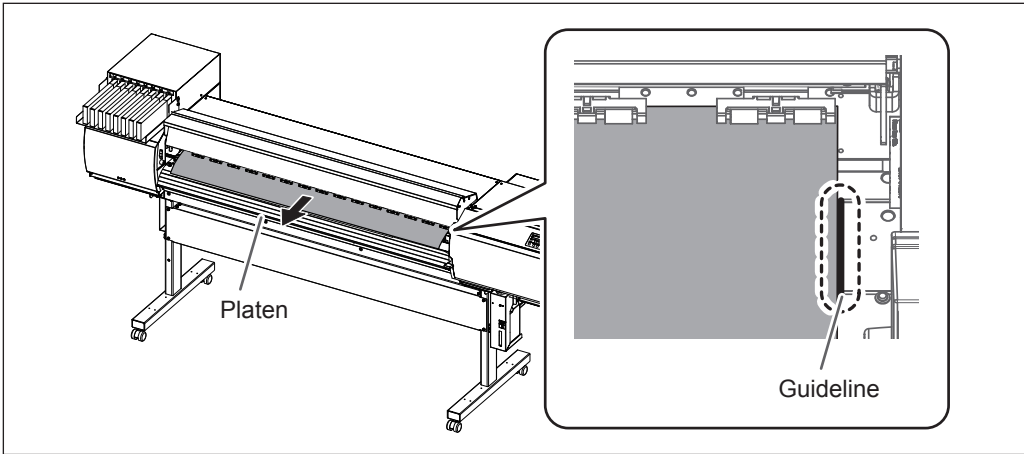

IMPORTANT!

If you want to readjust the media position at this step, go back to the procedure 1. and redo the procedure 1. - 4. Printing quality is affected due to skew media feed, if you hold the media only to readjust the position forcibly.

5 Hold the media at the center and pull it out, being sure to keep it straight and all areas of the media to be taut.

Confirm that the right edge of the media is aligned with the guideline.

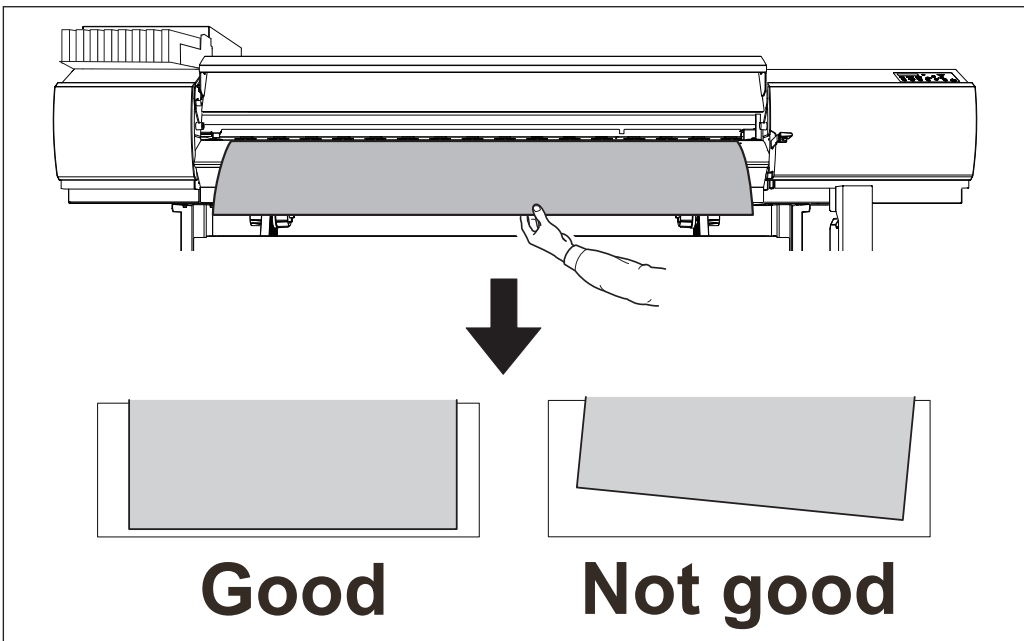

6

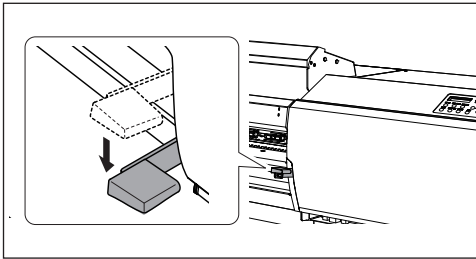

Down the loading lever (front).

The media is held in place.

7

Attach the media clamps that hold down the edges of the media.

The media clamps are magnetic, and the left and right clamps are distinct. Refer to the figure and install them at the correct positions, taking care not to let the left and right clamps get mixed up.

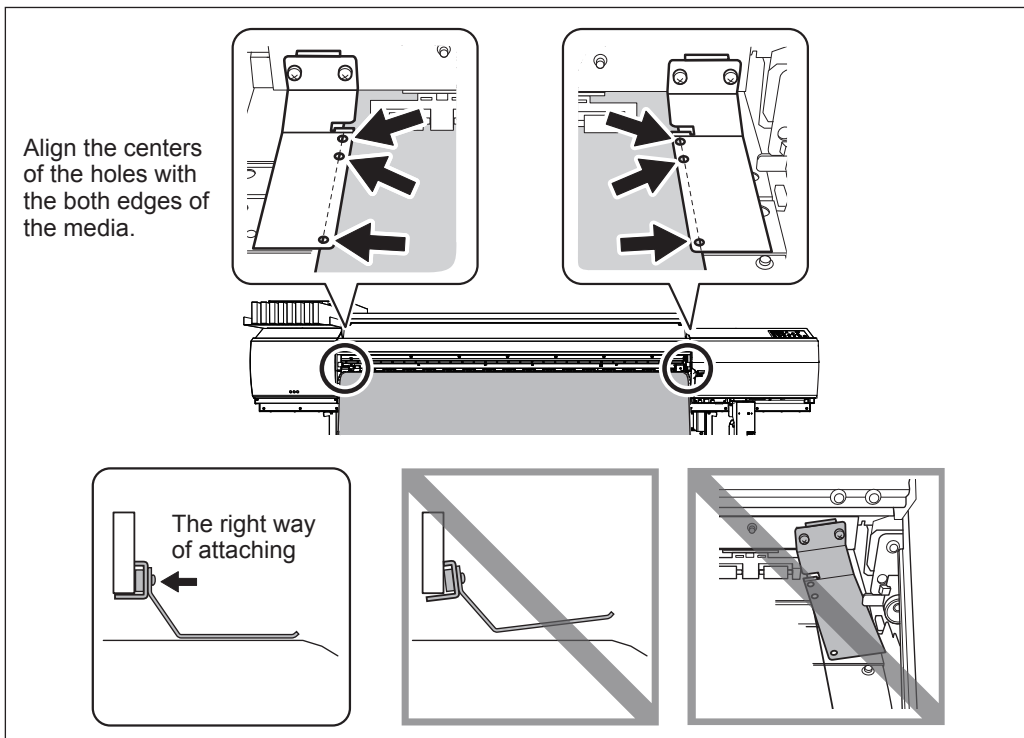

8

Close the front cover.

9

Press SET UP.

The print-head carriage moves and detects the width of media. This operation is called initialization. When initialization ends, SET UP remains steadily lighted, and the printable width is displayed on the display screen. This completes loading of the media.

IMPORTANT! Remove roll media when not in use.

If roll media is allowed to stand unused in a loaded state for an extended period, the media may sag. This can cause poor printing quality and motor errors, so be sure to remove and store such media when not in use.

Loading the Sheet Media

Procedure

- 1 Open the front cover.

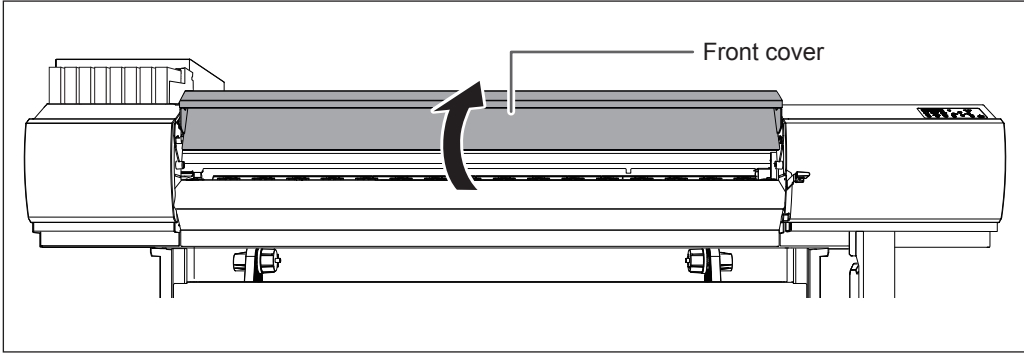

- 2 Move the media holders to the left and right.

Move them to a location where they don't disturb the media when the media is hung down from the rear of the machine. If they disturb the media, remove them with the shafts. For information on how to remove, refer to "Setup Guide."

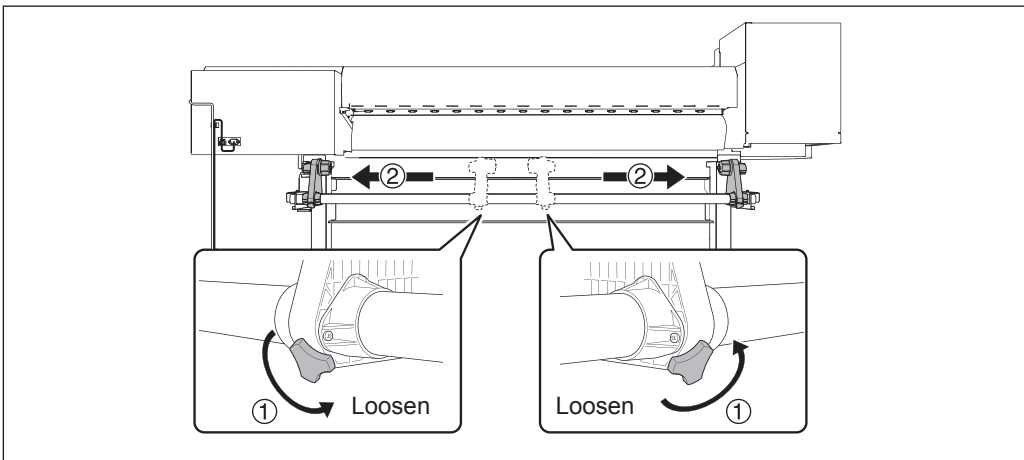

- 3 Pass the leading edge of the media between the pinch rollers and the grit rollers.

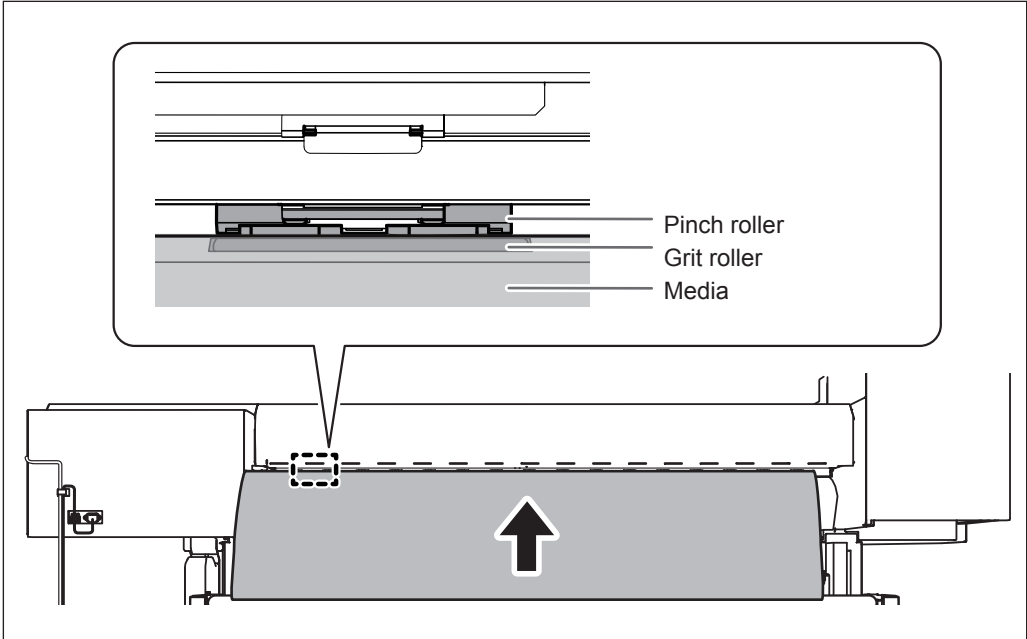

- 4

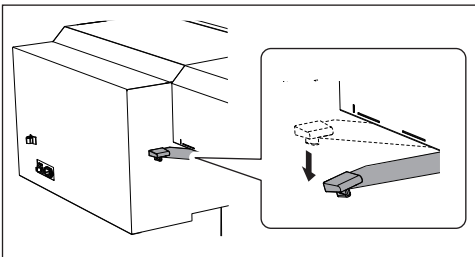

- Down the loading lever (rear).**
The media is held in place.

- 5

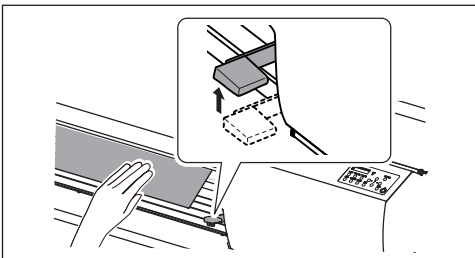

- While lightly pressing down the media, raise the loading lever (front).**
The media is released.

6 Align the front edge of the media with the location shown in the figure.

Line up the right edge of the media with the guide line, and align the front edge with the location shown in the figure. If the front edge of the media is cut at an angle, load the media so that its right edge is lined up straight with the guide line.

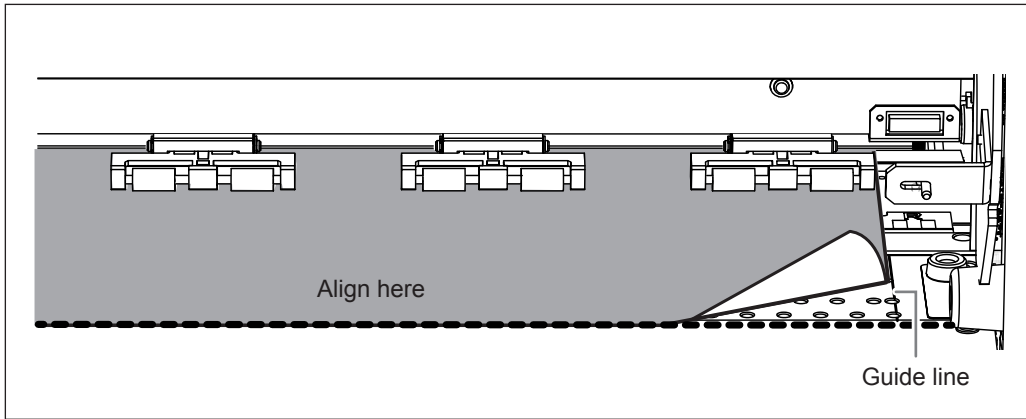

7

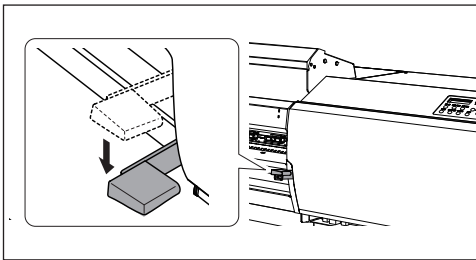

Down the loading lever (front).

The media is held in place.

8 Attach the media clamps that hold down the edges of the media.

The media clamps are magnetic, and the left and right clamps are distinct. Refer to the figure and install them at the correct positions, taking care not to let the left and right clamps get mixed up.

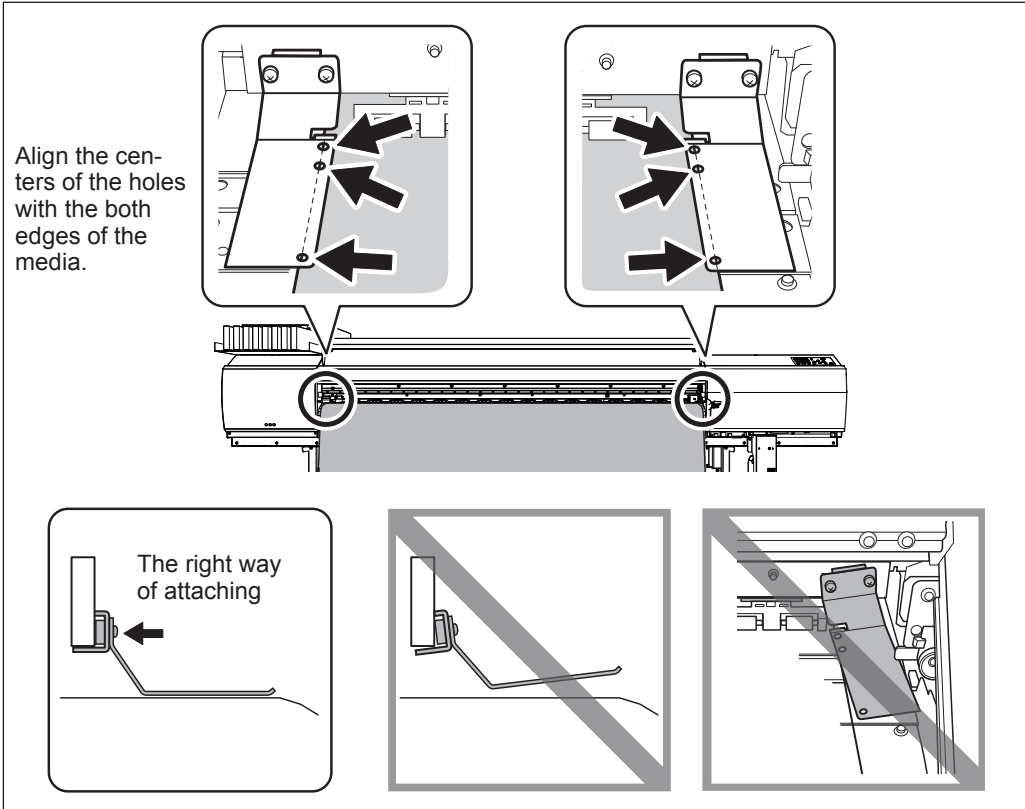

9 Close the front cover.

10 Press **SET UP.**





The print-head carriage moves and detects the width of media. This operation is called initialization. When initialization ends, **SET UP** remains steadily lighted, and the printable width is displayed on the display screen. This completes loading of the media.

Performing the Initial Adjustment (Correcting for Misalignment in Bidirectional Printing More Precisely)

Perform the initial adjustment of this machine. In the following case, perform this adjustment.

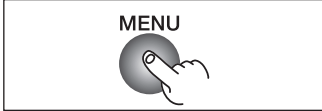
- When using this machine for the first time
- When changing the media to use
- When further correction is required to improve printing, such as when simple correction is performed for misalignment in bidirectional printing. (P. 99, "Correcting for Misalignment in Bidirectional Printing")

1. Print a test pattern.

- 1  Press **MENU**.
- 2  Press **▼** several times to display the screen shown on the left. Press **▶**, and then **▲**.
- 3  Press **▶**.
- 4  Press **ENTER**.
A test pattern is printed.
When printing ends, then press **▼**.

2. Read the correction values from the test pattern.

Choose the value that produces the least misalignment of 2 lines.

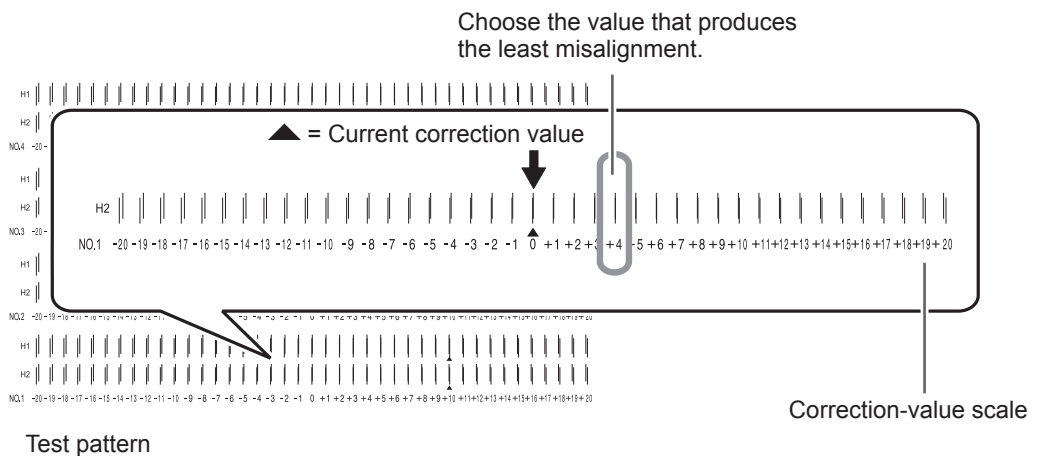

3. Enter the correction values that you read.

Enter the correction value for H2 and H1, respectively.





①

DETAIL SETTING	◀▶
SETTING NO. 1	▶

 Press .

②

H2	H1	◀▶
0	0	↵

 Press   to select H2 or H1.
Press   to select the correction value.
Select the values that you read at the step 2. for correction values.
When correction value settings end, press .

This completes [SETTING NO.1]. Subsequently, press  and set the correction values for [SETTING NO.2] to [SETTING NO.4] in the same manner.

③ Press   in this order to go back to the original screen.

Setup of Media

About [Media Setting] menu

To ensure the optimal output according to the media size and type, various setting items are provided in this machine. However, it is hard work to perform these settings one by one referring to this document. So, this machine provides the [Media Setting] menu that guides these settings in the interactive mode. Using this menu, you can set all of the basic settings only by setting according to the instructions on the display.

Since the setting details can be stored as the preset menu, you can promote your operation efficiently saving the setup steps when using the same type of media. Once storing the basic settings as the preset, you can do fine adjustment according to need.

The items set through the [Media Setting] menu can be also set individually.

Setup of Media ([Media Setting] menu)

Note: If any setting is not needed for each setting item, you can go to the next menu by selecting [NEXT].

1. Starting the [Media Setting] menu.

1 Load media.

Check that no sagging is found on the media. If any sagging exists, the followed correction value settings do not work effectively.

☞ P. 32, "Loading Media"

2

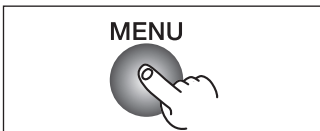

Press **MENU**.

3



When the left figure is displayed, press **ENTER**.

2. Set the temperature of preheater, print heater and dryer.

1

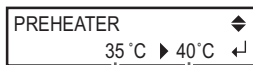

Current preset temperature Temperature to be set

Use **▲** **▼** to set the temperature.

Recommended temperature: 40 °C

Press **ENTER** to enable the setting.

2



Use **▲** **▼** to set the temperature.

Recommended temperature: 40 °C

Press **ENTER** to enable the setting.

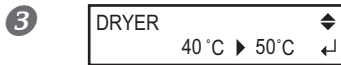

Use to set the temperature.

Recommended temperature: 50 °C

Press to enable the setting.

For the individual setting method of this setting item and the description, refer to P. 94, "Making the Temperature Setting for the Media Heating System"

To cancel the setting

Procedure

1 Press during the setting.



Press to select [YES].

Press .



The screen returns to the screen shown at the left.

By selecting [NO], the screen returns to the screen displayed when you pressed .

3. Adjusting the Print-Head Height.



Press to select [CHANGE].

Press to enable the setting.



When the left figure is displayed, open the front cover.

3 Move the height-adjustment lever to adjust the print-head height.

When moving to the [High] direction, the buzzer sounds twice, and to the [Low] direction, the buzzer sounds once.

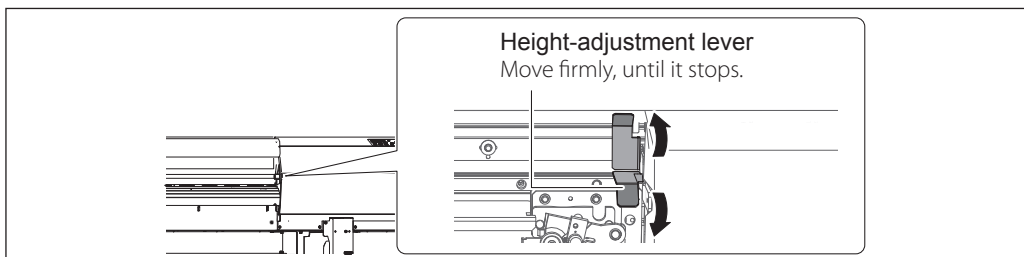

POINT!

Normally set to [Low]. For the media that is wrinkled and comes loose from the platen, set to [High].

4 Close the front cover.

For the individual setting method of this setting item and the description, refer to P. 101, "Adjusting the Print-Head Height to Match Media Thickness"

4. Perform the position correction of feed direction (alleviate horizontal stripes).

POINT!
Feed direction means the feed direction of the media. Perform the correction suitable for the media in advance because horizontal stripes are more likely to occur during printing when the moving distance of the media varies slightly depending on the type and thickness of media.

① CALIBRATION [SET] NEXT

Press **◀** to select [SET].
Press **ENTER** to enable the setting.
The test pattern of feed correction is output.

② INPUT ADJ. VALUES

When the left figure is displayed, press **ENTER**.

③ CALIBRATION 0.10% ▶ -0.10%

Use **▲** **▼** to set the correction value.
Press **ENTER** to enable the setting.

Current correction value Value to be set

To decide a correction value

Select the value to make the upper/lower rectangular gap and overlap smallest.

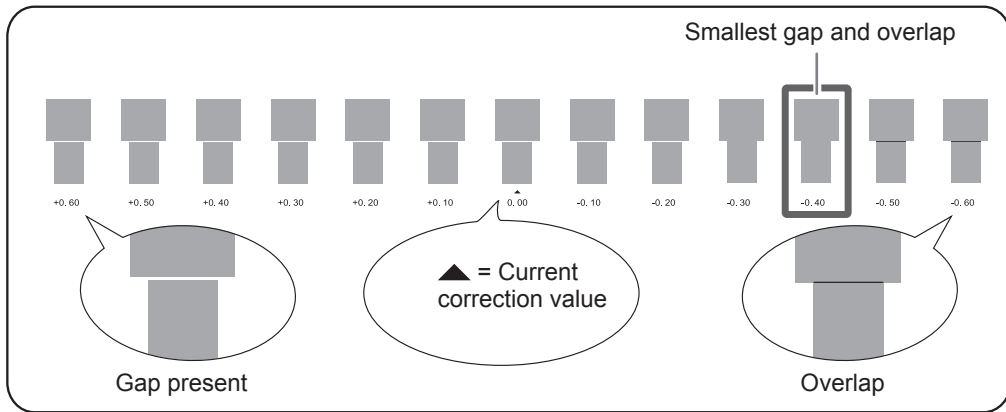

④ REDO ADJ.? YES [DONE]

[To confirm again / To adjust again]
Press **◀** to select [YES].
Press **ENTER** to enable the setting.

The test pattern of feed correction is output again. Go back to the procedure ③ and set again.

[To go to the next after correction is completed]
Press **▶** to select [DONE].
Press **ENTER** to enable the setting.

For the individual setting method of this setting item and the description, refer to P. 100, "Alleviating Horizontal Bands (feed correction function)"

5. Perform the correction for misalignment in bidirectional printing.

POINT!

This machine prints by the bidirectional mode (in which the print heads perform printing during both their outbound pass and return pass). This printing method is called "Bidirectional Printing." This method offers the advantage of being able to shorten output times, but subtle misalignment occurs during the outbound and return passes. The procedure to correct this and eliminate misalignment is "Bidirectional Correction."

1

ADJUST BI-DIR	◀ ▶
[SET] NEXT	↵

Press to select [SET].

Press to enable the setting.

The test pattern of bidirectional correction is output.

2

INPUT	↵
ADJ. VALUES	

When the left figure is displayed, press .

3

ADJUST BI-DIR	▲ ▼
0 ▶ -6	↵

Use to select the correction value.

Press to enable the setting.

Current correction value Value to be set

To decide a correction value

Choose the value that produces the least misalignment of 2 lines.

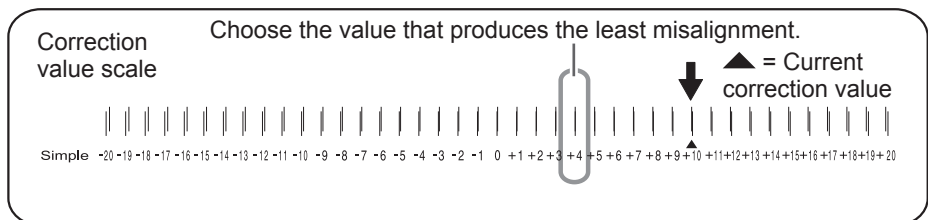

4

REDO ADJ.?	◀ ▶
YES [DONE]	↵

[To confirm again/adjust again]

Press to select [YES].

Press to enable the setting.

The test pattern of bidirectional correction is output again. Go back to the procedure 3 and set again.

[To go to the next after correction is completed]

Press to select [DONE].

Press to enable the setting.

For the individual setting method of this setting item and the description, refer to P. 99, "Correcting for Misalignment in Bidirectional Printing"

6. Set the Drying Method and Time after Printing.

- ①
- | | |
|--------------|----------|
| FEED FOR DRY | ◀ ▶ |
| DISABLE ▶ | ENABLE ◀ |
| ↓ | ↑ |
- Current setting Setting after changed
- Press to select the item.
Press to enable the setting.

POINT! **Drying method after printing**

Set whether the media should be fed until the trailing edge of the printed area is put on the dryer after the 1st page is printed. To make sure to dry the entire printed area, select [ENABLE]. If [DISABLE] is selected, the trailing edge of the printing area is not fed to the dryer unless you continue with a subsequent printing operation.

For the individual setting method of this setting item and the description, refer to P. 96, "Drying the Trailing Edge of the Printing Area on the Dryer"

- ②
- | | |
|-------------|---------|
| DRYING TIME | ◀ ▶ |
| 10min ▶ | 10min ◀ |
| ↓ | ↑ |
- Current setting Setting after changed
- Press to set the drying time.
Press to enable the setting.

Example of setting time (general guide)

NOTE : The setting time varies according to the type of media and the setting of printing quality.

Condition : Non-coated vinyl media

Setting time : About three minutes

POINT! **Drying time after printing**

Set the drying time after the 1st page is printed. The next operation is not started until the set time passes.

For the individual setting method of this setting item and the description, refer to P. 97, "Setting the Drying Time after Printing"

7. Save the setting as preset.

- ①
- | | |
|------------------|-----|
| PRESET | ◀ ▶ |
| [SAVE] NEXT | ↓ |
- Press to select [Save].
Press to enable the setting.
- If you select [NEXT], the performed settings are retained. But your settings are overwritten or deleted, when you operate the [Media Setting] menu again or switch off the main power of this machine.

2

SAVE	▲▼
NAME1	↵

Press ▲ ▼ to select the destination to save.
You can select one of NAME1 to 8.

Press ENTER to enable the setting.

3

SET NAME	◆▶
	↵

Press ▲ ▼ to select characters.

Press ▶ to move the next character.

Select the following characters in the same way.

You can enter up to 15 characters.

Press ENTER to enable the setting.



For the individual setting method of this setting item and the description, refer to P. 90, "Fully Utilizing Preset Function"

This completes the operation of the [Media Setting] menu.



Setting the Output-start Location

You can set the output-start location at any location you prefer (You can output if you do not set this). Note, however, that this setting must be made for each page as the setting returns to the default after each page is printed.



POINT!

Note, however, that the left and right positions are not restored to their defaults for test patterns.

Procedure

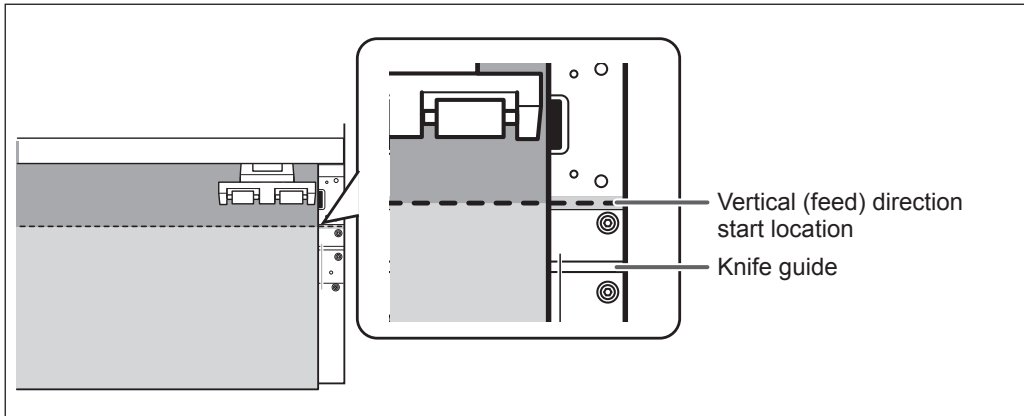
- 1 Open the front cover.
- 2 Set the output-start location in the vertical (feed) direction by moving the media with the press of  .



- 3 Set the output-start location in the horizontal (scan) direction by moving the print heads with the press of  .
- When a cursor key is pressed, preparations for moving the print heads are started. When the preparations are finished, move the print heads.

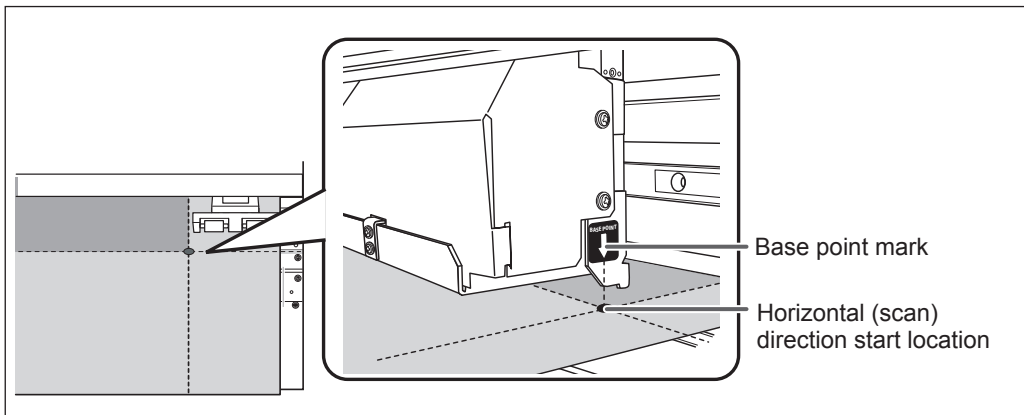

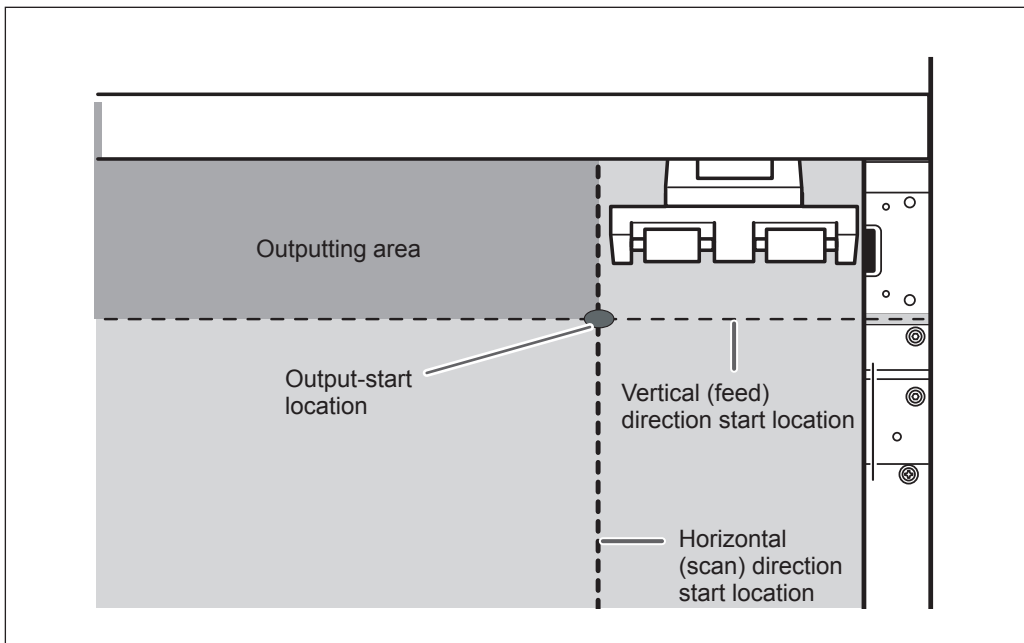

- 4 When the location is set, press **BASE POINT**.

W1100mm
B

BASE POINT remains steadily lighted and when the screen displays the character "B" together with the output-possible width at the location, setting is completed.

Printing Tests and Normal Cleaning

Before you carry out actual printing, we recommend performing a printing test to ensure no dot drop-out occurs. If dot drop-out occurs, perform cleaning of the print heads (Normal Cleaning).

How to Perform a Printing Test

Procedure

- 1 **Setting the Output-start Location.**

☞ P. 50, "Setting the Output-start Location"

- 2 Holding down **TEST PRINT** for one second or longer.

A test pattern is printed.

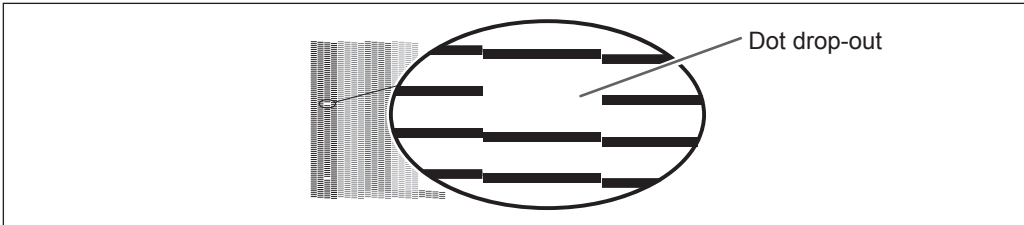

How to Perform a Normal Cleaning

Procedure

- 1 Press **CLEANING**.

- 2

CLEANING	◀▶
NORMAL CL.	▶

 Press **▶**.

- 3 Check the group with dot drop-out by viewing the printing-test results.

With normal cleaning, only groups of the print heads having dot drop-out are cleaned.

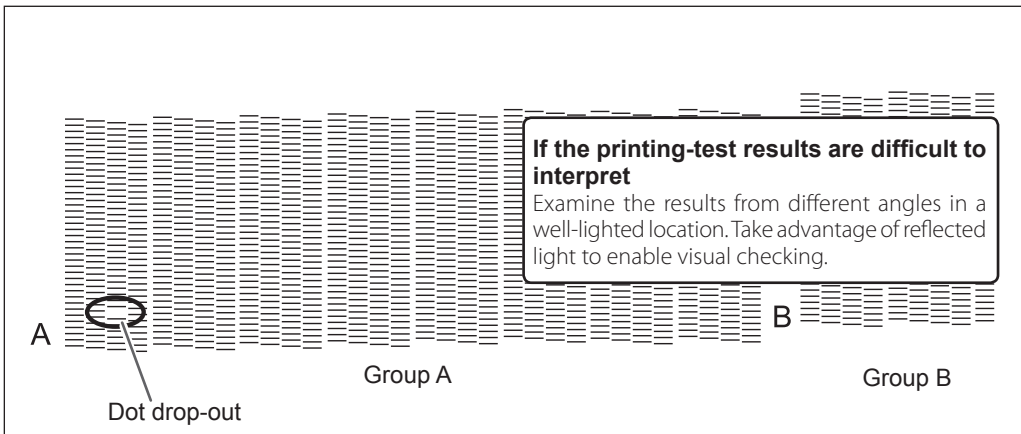

- 4

NORMAL CL.	◀▶
A B	↵

 Press **◀ ▶** to choose the group of print heads that is not to be cleaned.

Press **▲ ▼** to get rid of the group display.

Repeat this procedure to display the groups of only the print heads that require cleaning.

Only groups that is either A or B is displayed are objective for cleaning.

- 5 Press **ENTER**.

CLEANING...
>>>>

The screen shown in the figure appears and cleaning starts.

NORMAL CL. ◀▶
A B ↵

When it finishes, the screen shown in the figure appears again.

- 6 Press **MENU** **◀** in this order to go back to the original screen.

- 7 Perform a printing test again to make sure the dot drop-out has been corrected.

If the problem persists, try performing cleaning a second time. If the printer has been used for a long period, the problem may persist even after two or three-cycle cleaning. Then try cleaning using a different method.

☞ P. 66, "When Normal Cleaning Is Not Effective"

When You Want to Clean All Print Heads Simultaneously

Hold down **CLEANING** for one second or longer. Cleaning for all print heads starts automatically.

Getting Ready to Receive Data from a Computer

When P. 32, "Loading Media" and P. 53, "Getting Ready to Receive Data from a Computer" are completed, get ready to receive the data from a computer.

⚠ CAUTION

Never touch the print heads while output is in progress.

The print heads move at high speed. Hitting may cause injury.

Procedure

- 1 Close the front cover.
- 2 Make sure **SET UP** stays steadily lit.
If **SET UP** is not lit, down the loading lever and press **SET UP**.
- 3 Wait until **HEATER** stays steadily lit.

- 4 Make sure the top menu is displayed.
If the top menu is not displayed, press **MENU**, then press **◀**.

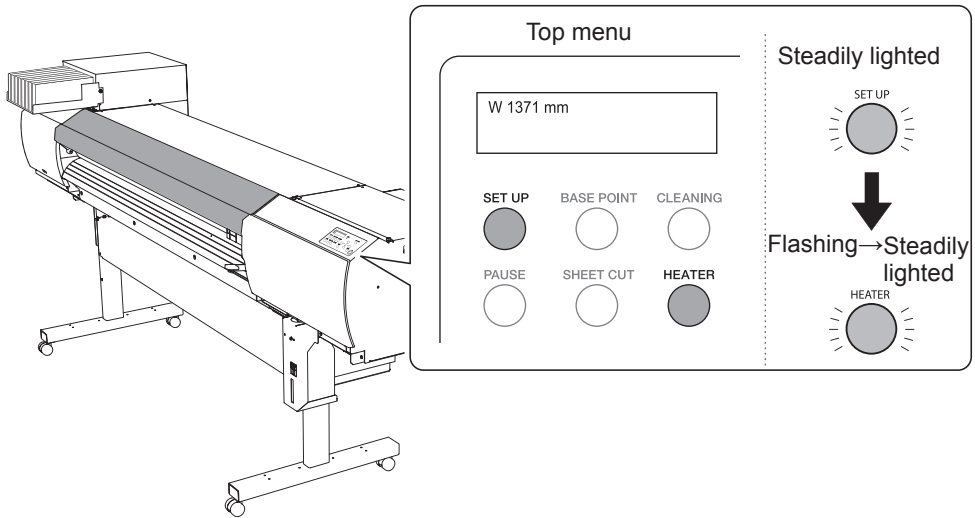

POINT!

Output is not possible in these situations.

- When a cover (front, L, R) is opened, the printer does not operate.
- Never open a cover (front, L, R) while output is in progress. Doing so will interrupt printing.
- Data from the computer is not accepted when **SET UP** is dark.
- Printing does not start until **HEATER** lights up. (If the print-heater and dryer are set to "OFF," printing is possible even if **HEATER** is not lit).
- Data from the computer is not accepted when you are not at the top menu.

Starting Output

When the operation of P. 53, "Getting Ready to Receive Data from a Computer" is completed, you can start output. To output, the following procedure is required.

① Creating Output Data

Create the output data using the application software like Adobe Illustrator and like that. For information on how to create the data, refer to the documentation of your application software.

② Sending the Output Data to This Machine Using the Software RIP.

Use the included software RIP "Roland VersaWorks." For information on how to install and use Roland VersaWorks, refer to "Roland VersaWorks Quick Start Guide" and HELP of Roland VersaWorks.

IMPORTANT! Points that must be observed

- Be sure to set the media clamps during printing. Otherwise the edges of the media may warp and catch on the print heads.
- During output, never touch the media that's already been discharged. Doing so may obstruct media feed or cause the media to rub against the print heads, which may result in a paper jam or damage to the print heads.
- Keep the loading lever raised when the machine is not in use.

POINT!

If ink runs out.

When ink runs out, a warning beep sounds and a slot number of which ink runs out is displayed on the display screen. Exchange the ink cartridge.

☞ P. 61, "How to Replace Ink Cartridges"

Before you perform lengthy printing, check the amount of ink remaining in the ink cartridges.

Before you perform lengthy printing, check the amount of ink remaining in the ink cartridges. When ink runs out and printing is paused, the coloring at the seam may be altered when printing resumes.

☞ P. 60, "Checking for Remaining Ink"

Pausing and Canceling Output

You can pause and cancel printing before it finishes. We do not recommend resuming outputting because horizontal stripes are produced at the place where output stopped.

Procedure

- 1** Press **PAUSE** before output finishes.

This pauses printing operation.

Press **PAUSE** again to resume printing.

To cancel the output, go the next procedure without pressing **PAUSE**.
- 2** TO CANCEL, HOLD
DOWN SETUP KEY **When the screen shown in the figure appears, hold down **SET UP** for one second or longer.**

This cancels printing operation.
- 3** Stop sending the output data from the computer.

Cutting Off the Media

Procedure

- 1** Close the front cover.
- 2** Make sure **SET UP** lights up.
- 3** Hold down **SHEET CUT** for one second or longer.

The media is cut off.

REMOVE
MEDIA CLAMPS ↵ When the media clamps are attached, the screen shown in the figure appears. Open the front cover, remove the right and left media clamps, and then press **ENTER**.

To cancel cutoff, press **◀**.

The cutoff location on the media is as shown in the figure on the next page.

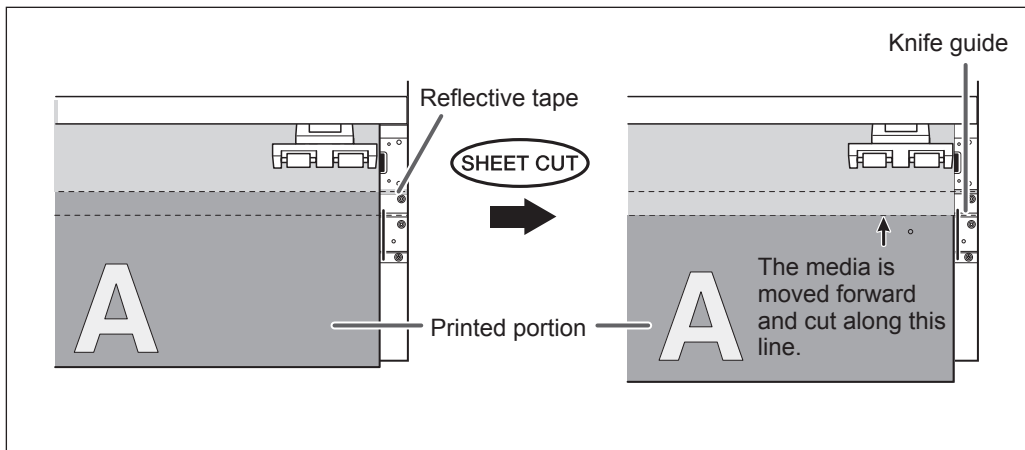

You can make the setting in the software RIP for automatic media cutoff after printing or cutting has finished. For information on how to make the setting, refer to the documentation for the software RIP you're using.

IMPORTANT! Cut-off operations

- Be sure to detach the media clamps. Performing cutoff with the media clamps remaining attached may cause the operation to be interrupted due to detection of the media clamps.
- If the media clamps are present on the machine when the setting to execute automatic cutoff of the media is made on the computer, the media clamps are detected and no cutoff operation is performed.
- Before you're performing cutoff, never use  to pull the media back. Unless the end of the media has been pulled out to a location to the front of the platen, cutoff may not be performed smoothly.

IMPORTANT! Give attention to media composition.

- For some types of media, cutoff is not possible.
- Some types of media may remain on the platen after cutoff. If the media remains on the platen, remove it by hand.

Switch Off

Switch Off

⚠️ WARNING

When output is not being performed, remove any loaded media or switch off the sub power.

The continued application of heat at a single location may cause the release of toxic gases from the media or pose a fire hazard.

2

Basic
Operation

Procedure

1

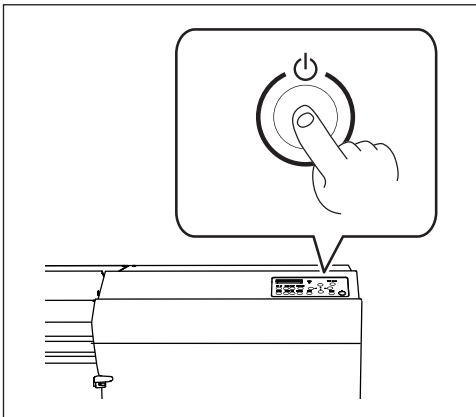

Hold down the sub power button for one second or longer.

The sub power is turned off. Perform this process after output is finished.

2

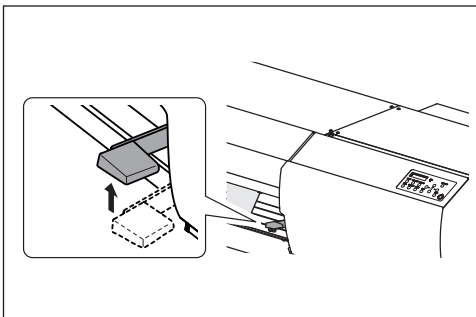

Raise the loading lever (front).

Raise the loading lever when the machine is not used even if the power is not turned off.

IMPORTANT!

Leave the main power switched on at all times.

Never switch off the main power. By switching on the main power, the automatic maintenance function is carried out periodically. If the automatic maintenance is not carried out, it may result in breakdown of this machine such as breakdown of the print heads.

Never switch off the main power or unplug the power cord suddenly while operation is in progress.

Switching off the main power or unplugging the power cord suddenly while operation is in progress may damage the print heads. Be sure to first switch off the sub power. If the main power switch is turned off by mistake, immediately turn the main and sub power switches back on.

Chapter 3

Maintenance:

For always using the printer in the best condition

Checking for Remaining Ink and Replacing Cartridges	60
Checking for Remaining Ink	60
How to Replace Ink Cartridges.....	61
Maintenance that Should Be Performed Daily	62
Disposing of Discharged Ink.....	62
Cleaning	64
About Care and Maintenance of The Print Heads.....	65
When Normal Cleaning Is Not Effective.....	66
Medium Cleaning.....	66
Powerful Cleaning	67
When Uneven Color Issue Occurs.....	68
Light Choke Cleaning	68
Maintenance that Should Be Performed More Than Once a Month....	69
When Manual-Cleaning Becomes Necessary.....	69
Manual Cleaning.....	70
When Problems Such As Dot Drop-out are Not Cleared Up	76
When Problems Such As Dot Drop-out are Not Cleared Up	76
Replacing Consumable Parts	78
Replacing the Wipers	78
Replacing the Felt Wipers	81
Replacing the Separating Knife.....	84
When Not in Use for a Prolonged Period.....	86
Keep Performing Maintenance	86
Alarm Feature.....	86
Special maintenance.....	87
Draining Ink and Performing Internal Washing	87
Draining Ink Remaining Inside the Machine	87

Checking for Remaining Ink and Replacing Cartridges

Checking for Remaining Ink

Procedure



1 Press **MENU**.

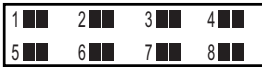

Press  several times until the screen shown on the left appears.

Press .



 indicates the amount of ink remaining. When there are more , the amount of ink remaining is larger.

NOTE: The display shows an approximate guide to the amount of remaining ink. It may differ somewhat from the actual amount remaining.

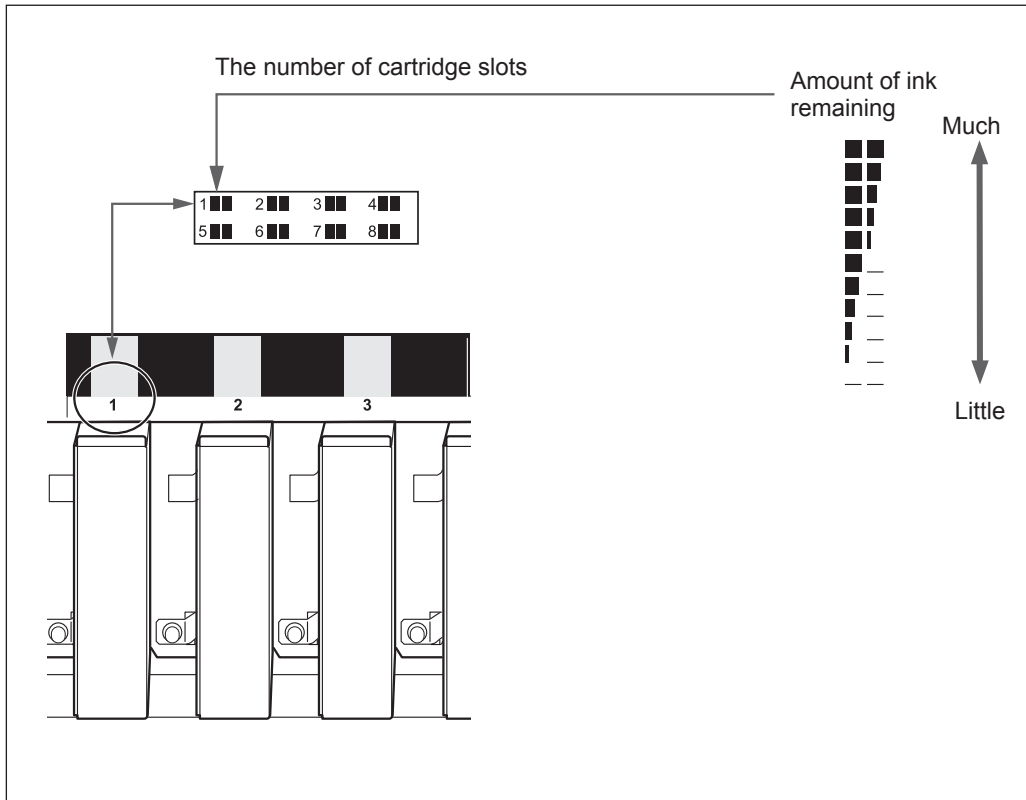

3 Press **MENU**  in this order to go back to the original screen.

How to Replace Ink Cartridges

When ink runs out, a warning beep sounds and printing pauses (unless the factory default settings have been changed). Pull out the empty cartridge and insert a new one. Printing resumes.

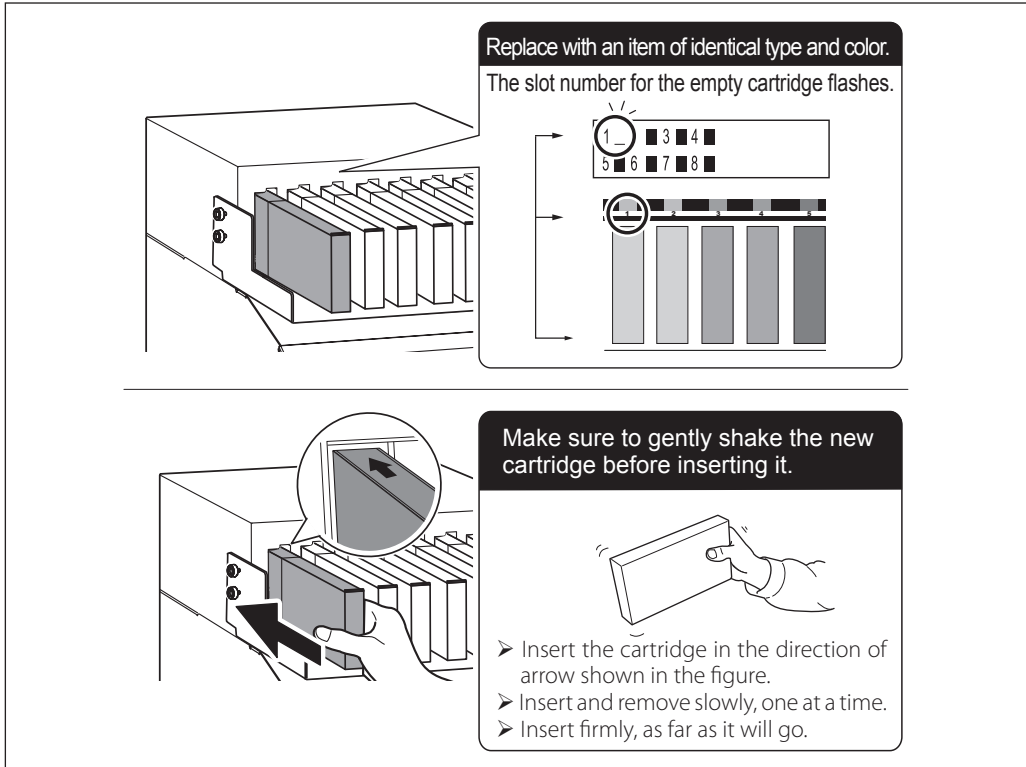

IMPORTANT! Important notes on replacing cartridges

- Insert and remove slowly, one at a time.
- Be sure to replace with an item of identical type.
- Never use an ink cartridge which has already been used in other machines even if it is of the identical type.
- Never mix items of different types.
- Never allow the machine to stand with an ink cartridge removed. The print heads may become clogged.
- Never insert or remove a partially used ink cartridge.
- Never remove an ink cartridge suddenly while the printer is in operation.

⚠ WARNING

Never store ink, cleaning liquid, or discharged fluid in any of the following locations.

- Any location exposed to open flame
- Any location where high temperature may occur
- Near bleach or any other such oxidizing agent or explosive material
- Any location within the reach of children

Fire may be a danger. Accidental ingestion by children may pose a health hazard.

Maintenance that Should Be Performed Daily

Disposing of Discharged Ink

CHECK
DRAIN BOTTLE

The drain bottle collects discharged fluid. Dispose of collected material before the bottle becomes full. The message shown in the figure appears when a certain amount of discharged fluid has collected in the bottle. Follow the procedure below to discard the discharged fluid.

Procedure

1 CHECK
DRAIN BOTTLE

When the message shown in the figure appears, press **ENTER**.

2 Press **MENU**.

3 MENU
SUB MENU

Press **▼** several times until the screen shown on the left appears.

Press **▶**, and then **▲**.

4 SUB MENU
MAINTENANCE

Press **▶**, and then **▲**.

5 MAINTENANCE
DRAIN BOTTLE

Press **ENTER**.

6 EMPTY
DRAIN BOTTLE

When the screen shown on the left appears, detach the bottle, discard the discharged fluid to empty it.

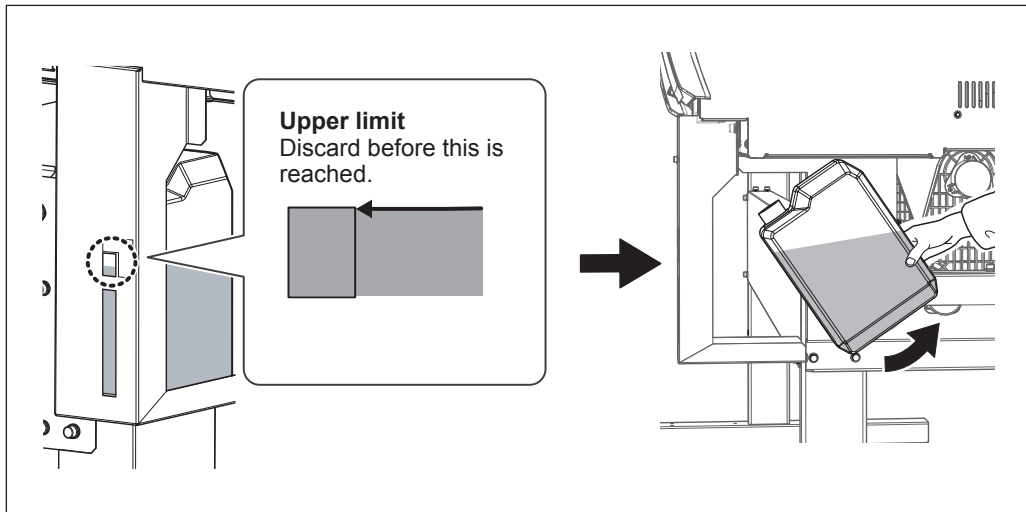

⚠ CAUTION

Before you detach the drain bottle, be sure to wait for the screen to display **"EMPTY DRAIN BOTTLE."**

Failing to follow this procedure may cause discharged fluid to flow out of the tube and spill, soiling your hands or the floor.





7 **Attach the emptied drain bottle to the machine.**
Press  .



8 **Press**  .

9 **Press**   **in this order to go back to the original screen.**

 **WARNING** **Never place discharged fluid and ink near open flame.**
Doing so may cause fire.

 **CAUTION** **To store discharged fluid temporarily, place it in the included drain bottle or in a durable sealed container such as a metal can or polyethylene tank, and cap tightly.**
Any spillage or vapor leakage may cause fire, odor, or physical distress.

Dispose discharged fluid properly, in accordance with the laws in effect in your local.
Discharged fluid is flammable and contains toxic ingredients. Never attempt to incinerate discharged fluid or discard it with ordinary trash. Also, do not dispose of it in sewer systems, rivers, or streams. Doing so may have an adverse impact on the environment.

Cleaning

⚠️ **WARNING**

Never use gasoline, alcohol, thinner, or any other flammable material. Doing so may cause fire.

⚠️ **CAUTION**

Before attempting cleaning, switch off the sub power and wait until the platen and dryer cool (approximately 30 minutes). Sudden movement of the machine may cause injury, or hot components may cause burns.

Wipe away any buildup of ink or grime on the media path and other locations as daily cleaning. In particular, the pinch rollers, grit rollers, and platen are likely to get a buildup of grime. Clean by wiping with a cloth moistened by neutral detergent diluted with water then wrung dry.

3

Maintenance

POINT!

- This machine is a precision device, and is sensitive to dust and dirt. Perform cleaning on a daily basis.
- Never attempt to oil or lubricate the machine.

Pinch rollers

Periodically wipe away any grime. Failure to clean properly may result in the transfer of grime to the surface of media.

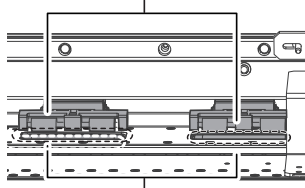

Grit rollers

Remove buildup of media and other material using a brush. Never use a metal brush.

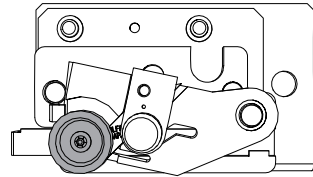

Roller of the separating knife

Paper dust is likely to deposit on this roller. Wipe the roller regularly. Failure to clean properly may result in the transfer of grime to the surface of media.



Wipe away any buildup of ink or grime on the media path.

About Care and Maintenance of The Print Heads

Care of the print heads is essential to ensuring optimal printing at all times. There are daily care and periodic care.

Daily Care and Maintenance

➤ **Test print and normal cleaning**

It is recommended to perform the normal cleaning before daily operation.

☞ P. 51, "Printing Tests and Normal Cleaning"

Cleaning at Occurrence of Uneven Color Issue

➤ **Light choke cleaning**

Perform this cleaning when color is uneven and unstable, i.e. darkness or brightness is different although the same data is printed with the same settings.

☞ P. 68, "When Uneven Color Issue Occurs"

Periodic Care and Maintenance

➤ **Medium cleaning/Powerful cleaning**

Perform the medium cleaning or powerful cleaning when the problems such as dot drop-out are not cleared up by the normal cleaning.

☞ P. 66, "Medium Cleaning"

☞ P. 67, "Powerful Cleaning"

➤ **Manual Cleaning**

Based on your frequency of use, perform the manual cleaning periodically.

☞ P. 66, "Medium Cleaning"

NOTE : The print heads are components that wear out. Periodic replacement is required, with the frequency of replacement depending on use. Purchase them from your authorized Roland DG Corp. dealer.

When Normal Cleaning Is Not Effective

POINT!

Note, however, that the medium and powerful cleaning consumes more ink than normal cleaning, and too-frequent use may damage print heads themselves. Avoid using it more than necessary.

Medium Cleaning

If normal cleaning (P. 51, "Printing Tests and Normal Cleaning") does not fix dot drop-out, perform more powerful "Medium Cleaning" to remove clogging from the print heads.

Procedure

1 Perform a printing test.

☞ P. 51, "How to Perform a Printing Test"

When a printing test is completed, be sure to remove the media.

2 Press **CLEANING**.

3



Press **▼** to display the left figure.
Press **▶**.

4 Check the group with dot drop-out by viewing the printing-test results.

With medium cleaning, only groups of the print heads having dot drop-out are cleaned.

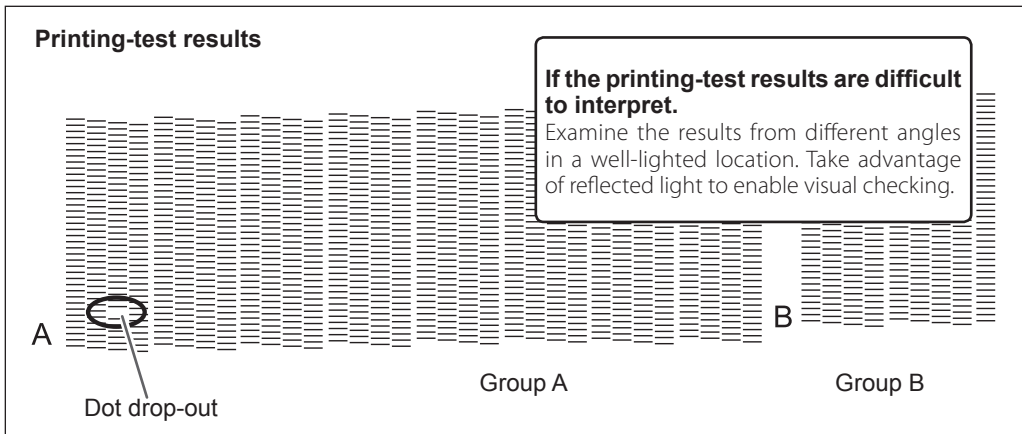

5

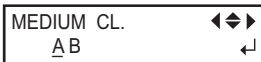

Press **◀** **▶** to choose the group of the print heads that is not to be cleaned.

Press **▲** **▼** to get rid of the group display.

Repeat this procedure to display the groups of only the print heads that require cleaning.

Only groups that is either A or B is displayed are objective for cleaning.

- 6 Press **ENTER** .

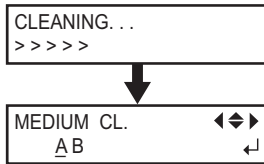

The screen shown in the figure appears and cleaning starts.

When it finishes, the screen shown in the figure appears again.

- 7 Press **MENU** **←** in this order to go back to the original screen.

Perform stronger "powerful cleaning" when the problems such as dot drop-out are not cleared up by the medium cleaning.

Powerful Cleaning

Procedure

- 1 Press **CLEANING** .



Press **▲** to display the left figure.

Press **ENTER** .

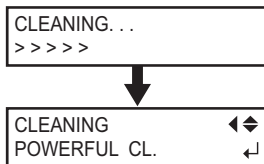

The screen shown in the figure appears and cleaning starts.

When it finishes, the screen shown in the figure appears again.

- 3 Press **MENU** **←** in this order to go back to the original screen.

When powerful cleaning is not effective

When the problems such as dot drop-out are not cleared up even by performing powerful cleaning several times, perform "Manual Cleaning." Such cleaning can be effective when carried out periodically, according to the frequency of use.

☞ P. 70, "Manual Cleaning"

When Uneven Color Issue Occurs

Light Choke Cleaning

POINT!

Light choke cleaning consumes ink as much as powerful cleaning does. Performing light choke cleaning frequently may damage the print heads themselves. Avoid using it more than necessary.

Perform this cleaning when color is uneven and unstable, i.e. darkness or brightness is different although the same data is printed with the same settings.

Procedure

3

Maintenance

1 Press **MENU**.



Press **▼** several times until the screen shown on the left appears.

Press **▶** twice.



Press **▶**.

Press **▲**.



Press **ENTER**.

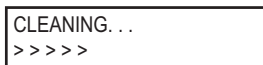

The screen shown in the figure appears.



When it finishes, the screen shown in the figure appears again.

IMPORTANT!

Never remove ink cartridges during cleaning.

If an ink cartridge is removed while ink filling is in progress, [CLEANING ERROR] appears on the display screen to disable the continuance of cleaning. In that case, refer to P. 134, "[CLEANING ERROR]" to recover from the error, and start from the beginning again.

5 Press **MENU** **◀** in this order to go back to the original screen.

If the output color is still unstable after the light choke cleaning, contact your authorized Roland DG Corp. dealer.

Maintenance that Should Be Performed More Than Once a Month

When Manual-Cleaning Becomes Necessary

Perform The Manual Cleaning More Than Once a Month.

To keep the stable output condition at all times, perform the manual cleaning more than once a month. The manual cleaning takes approximately 10 minutes.

The Manual Cleaning is Recommended When The Following Symptoms Occur.

It is recommended to perform the manual cleaning when any of the symptoms given below occurs and it cannot be solved by the automatic cleaning functions such as the normal cleaning.

For your information, replacement of the wiper or felt wiper is also effective to improve the symptoms.

☞ P. 78, "Replacing the Wipers"

☞ P. 81, "Replacing the Felt Wipers"

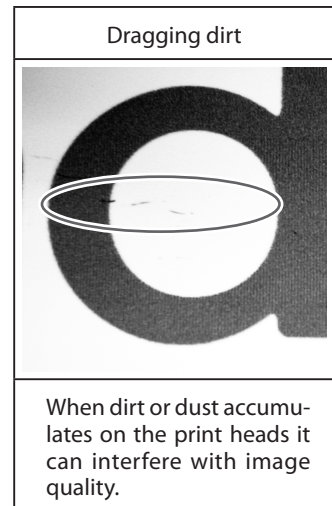
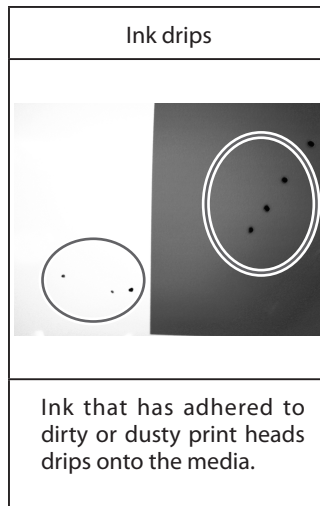
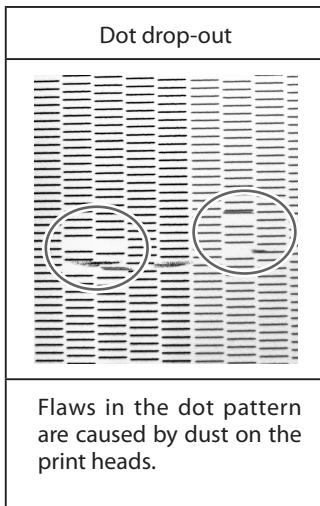

- When the cleaning stick and cleaning liquid for the manual cleaning runs out, place an order for them with your authorized Roland DG Corp. dealer.
- The print heads are components that wear out. Periodic replacement is required, with the frequency of replacement depending on use. Purchase them from your authorized Roland DG Corp. dealer.

Manual Cleaning

IMPORTANT!

Important notes on this procedure

- Before attempting this operation, remove any media.
- To prevent the print heads from drying out, finish this procedure in 30 minutes or less. A warning beep sounds after 30 minutes.
- Never use any implement other than the included cleaning stick. Cotton swabs or other lintproducing items may damage the print heads. If you use up the cleaning stick, purchase a new one from your authorized Roland DG Corp. dealer.
- Use one cleaning stick per cleaning session, then discard the stick after use. Reusing cleaning sticks may reduce printing quality.
- Do not put the cleaning stick used for cleaning into the cleaning liquid. It will deteriorate the liquid.
- Never rub the nozzle surface of the print heads.
- Stroke the sponges very gently, applying as little pressure as possible. Never rub, scrape, or crush them.

When a warning beep sounds during cleaning.

A warning beep sounds in 30 minutes after the operation is started. At this time, stop work, and attach cover L and cover R, then close the front cover. Press **ENTER** to quit the manual-cleaning menu. After that, restart the procedure from the beginning.

⚠ CAUTION

Be sure to perform operations as specified by the instructions above, and never touch any area not specified in the instructions. Sudden movement of the machine may cause injury.

1. Enter the manual-cleaning menu.

1 Remove any media

2 Press **MENU**.

3

MENU	◀◆
SUB MENU	▶

Press **▼** several times until the screen shown on the left appears.

Press **▶**, and then **▲**.

4

SUB MENU	◀◆
MAINTENANCE	▶

Press **▶**.

5

MAINTENANCE	◀◆
CLEANING	↵

Press **ENTER**.

6

OPEN COVER R

When the screen shown on the left appears, open the cover R.

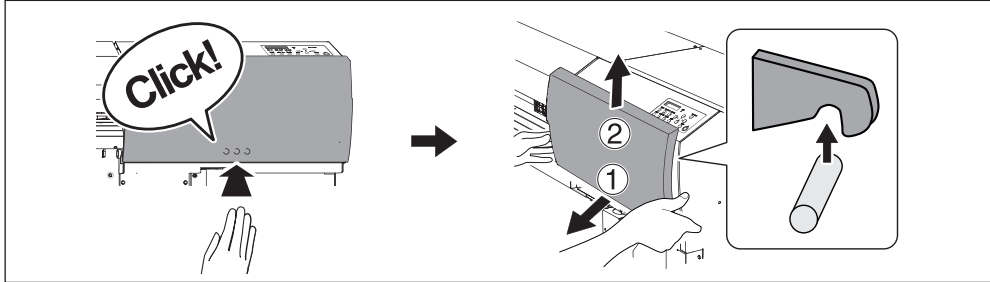

FINISHED?

Preparations are complete when this screen appears.

2. Clean the wipers using the cleaning stick.

NOTE : Clean the two wipers one by one.

1

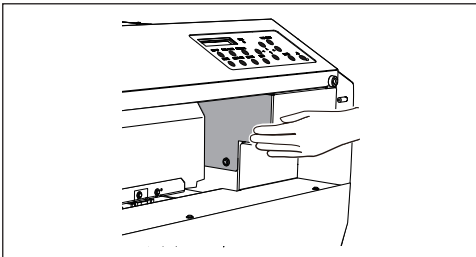

Touch the location shown in the figure to discharge any static electricity.

2

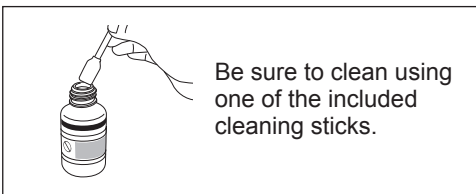

Moisten the cleaning stick with the cleaning liquid.

3

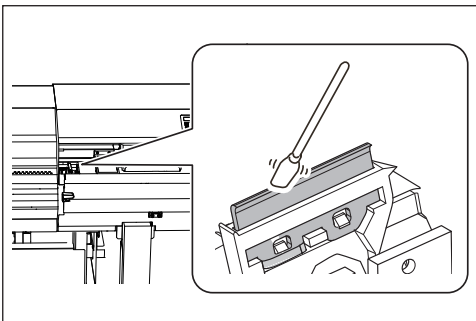

Clean the first wiper.

4

When cleaning is finished, press **ENTER**.

5

OPEN COVER R

Close the cover R.

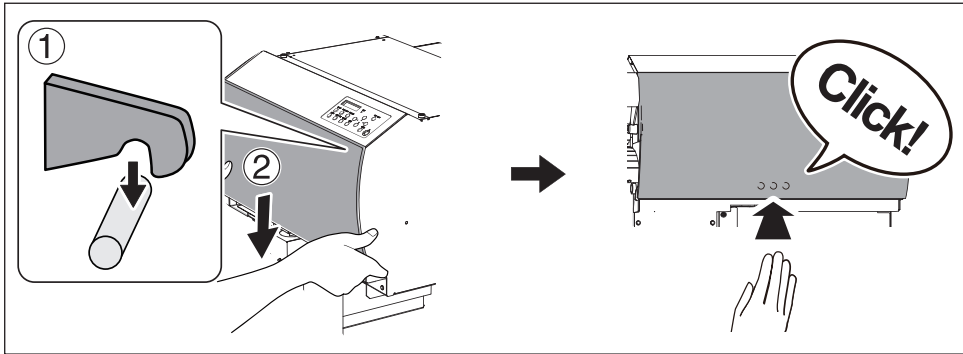

6

OPEN COVER R

When the screen shown on the left appears, open the cover R.

FINISHED? ↵

Preparations are complete when this screen appears.

7

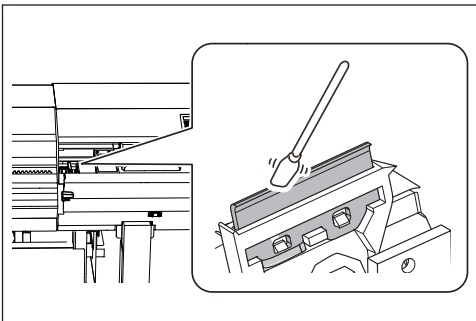

Clean the second wiper.

8

When cleaning is finished, press **ENTER**.

9

CLOSE COVER R

Close the Cover R.

3. Clean the area around the print heads with the cleaning stick.

1 OPEN COVER L Open the cover L.

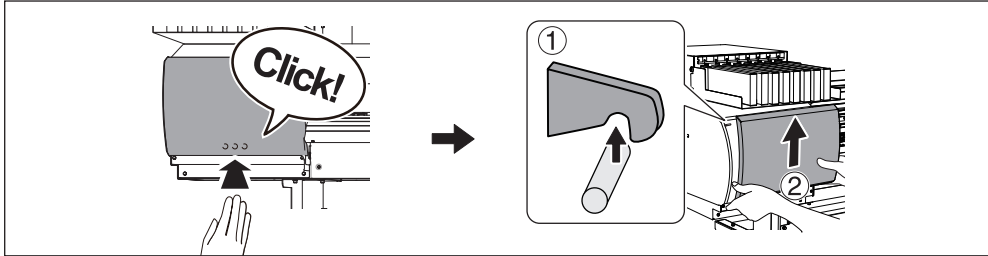

REMOVE CUT RAIL ↵ Remove the cut rail.
Press ENTER .

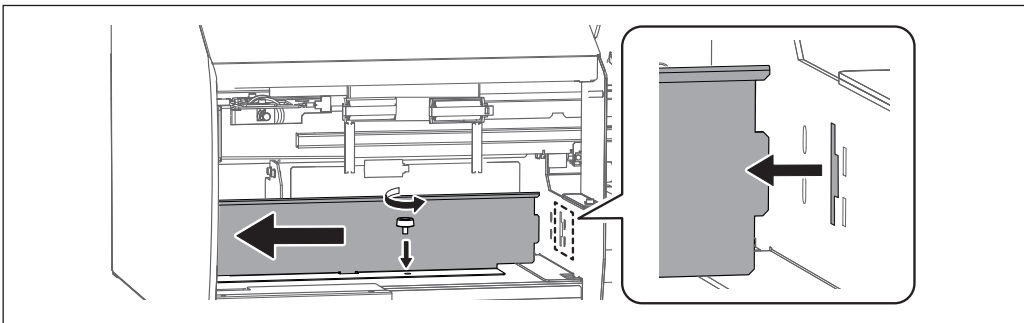

2 CLOSE COVER L Close the cover L.

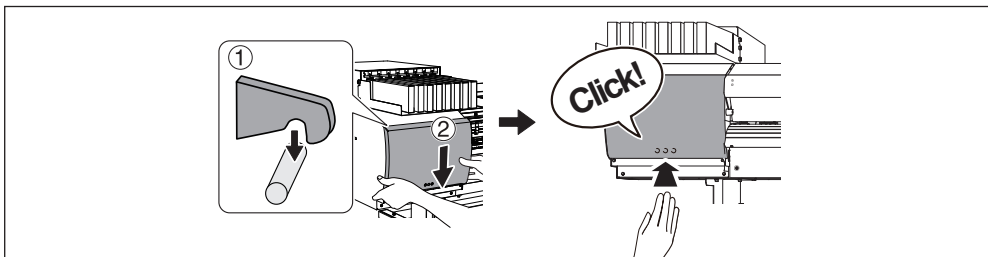

3 OPEN COVER L Open the cover L.

4 OPEN COVER R Open the cover R.

FINISHED? ↵ Preparations are complete when this screen appears.

5

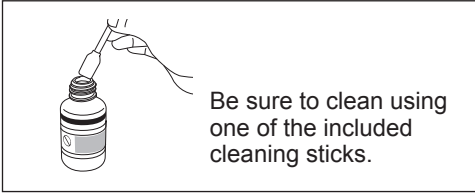

Moisten the cleaning stick with the cleaning liquid.

6

Perform cleaning in the place shown in the figure below.

Be especially careful to clean away any fibrous dust (lint).

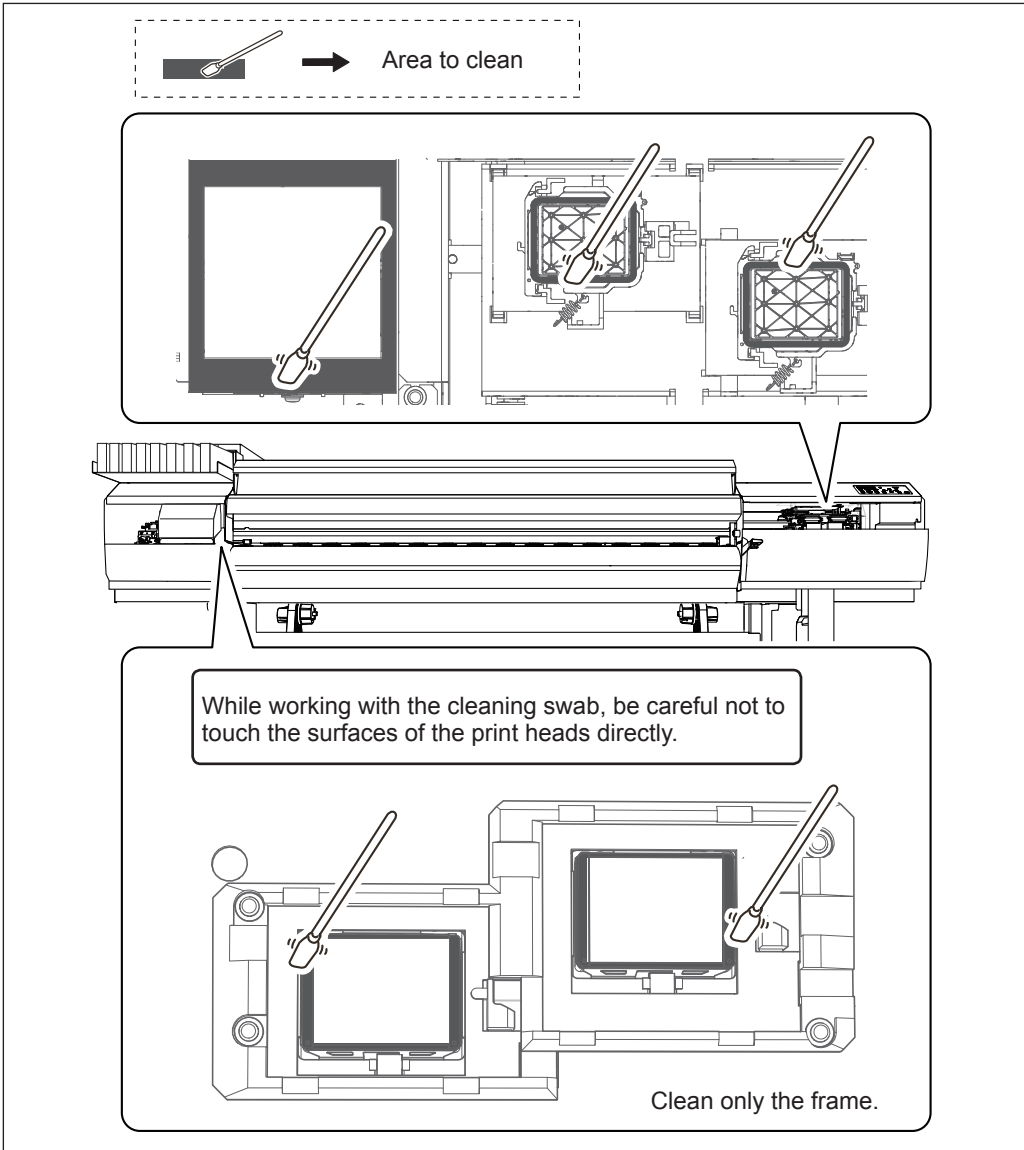

7

When cleaning is finished, press **ENTER**.

4. Reattach cover L, cover R, and quit the manual cleaning menu.

- | | | |
|----------|-----------------------|---|
| 1 | CLOSE COVER L | Close the cover L. |
| 2 | CLOSE COVER R | Close the cover R. |
| 3 | OPEN COVER L | Open the cover L. |
| 4 | REPLACE CUT
RAIL ↵ | Replace the cut rail.
Press ENTER. |

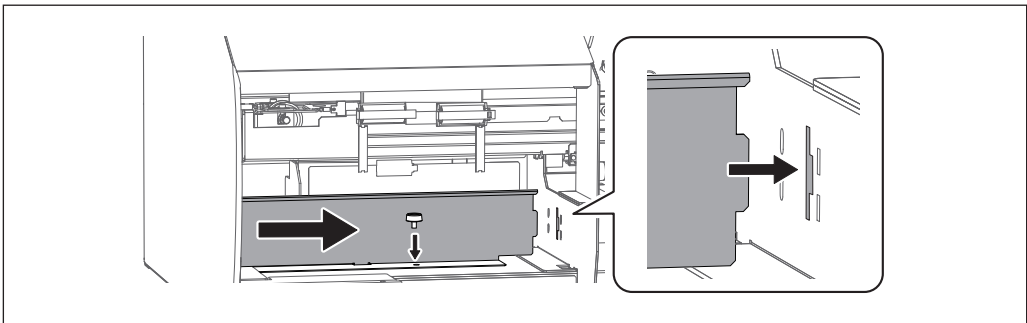

- | | | |
|----------|-----------------------------|---|
| 5 | CLOSE COVER L | Close the cover L. |
| | CLEANING...
>>>> | The screen shown in the figure appears and cleaning starts. |
| | ↓ | |
| | MAINTENANCE
CLEANING ⏮ ⏭ | When it finishes, the screen shown in the figure appears again. |
- 6** Press MENU ◀ in this order to go back to the original screen.

5. Perform a printing test to verify the results of the procedure.

Perform a printing test to check the results.

Perform cleaning using the machine's cleaning feature several times when necessary.

☞ P. 51, "Printing Tests and Normal Cleaning"

When Problems Such As Dot Drop-out are Not Cleared Up

When Problems Such As Dot Drop-out are Not Cleared Up

When flaws in the dot pattern such as dot drop-out are not cleared up even after performing cleaning using the cleaning function (normal, medium, or powerful) or manual cleaning, perform the operation described below.

IMPORTANT!

A large amount of ink will be discharged during this operation. Perform this operation only when dot drop-out cannot be cleared up even after performing cleaning using the cleaning function (normal, medium, or powerful) or manual cleaning.

☞ P. 69, "Maintenance that Should Be Performed More Than Once a Month", P. 66, "When Normal Cleaning Is Not Effective", P. 69, "Maintenance that Should Be Performed More Than Once a Month"

Procedure

1 Discard the discharged fluid in the drain bottle.

By referring to P. 62, "Disposing of Discharged Ink", dispose of the discharged fluid. Start from step 2.

CAUTION

Be sure to discard the discharged ink at this step.

A large amount of ink will be discharged during this operation. Be sure to discard the discharged ink at this step. If you do not discard the discharged ink at this step, the discharged ink might overflow from the drain bottle during the subsequent process.

2 Press **ENTER**.



Press **▼** several times until the screen shown on the left appears.

Press **▶**.

Press **▲** twice.



Press **▶**.

Press **▲** twice.



Press **ENTER**.



Check that the drain bottle is empty and press **ENTER**.



The screen shown in the figure appears.



When it finishes, the screen shown in the figure appears again.

7 Press **MENU** **◀** in this order to go back to the original screen.

POINT! **Cleaning of the surface of the print heads as an emergency measure**

When dot drop-out or dot deflection is not improved even if cleaning is performed several times, you can clean the surface of the print heads as an emergency measure. Since the surface of the print heads has an extremely delicate mechanism, make sure to perform the operation carefully and deliberately. Note that this operation is an emergency measure. It may damage defect-free parts depending on the symptom, deteriorating it. If you have any questions, contact your authorized Roland DG Corp. dealer.

Procedure

- 1** **Moisten the cleaning stick with the cleaning liquid.**
- 2** **Softly press the cleaning stick to the surface of the print heads.**
Press it gently and softly so that the surface of the print heads is permeated with the cleaning liquid. Never rub the stick on the surface and press it forcibly.

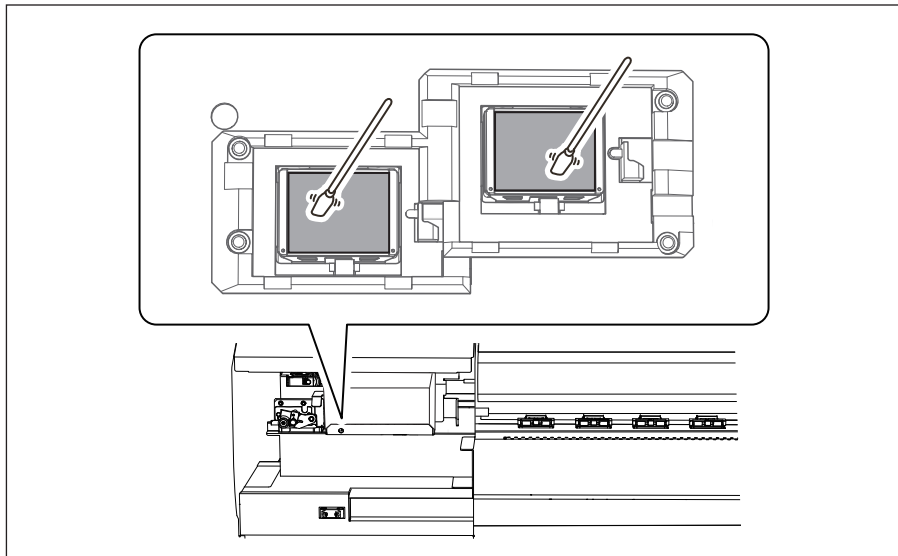

Replacing Consumable Parts

Replacing the Wipers

The wiper is a component that you use when cleaning the print heads. When the screen displays a message like the one shown, it means the item needs to be replaced. There are two wipers. Replace both wipers with new ones.



Regarding the purchase of the wiper, contact your authorized Roland DG Corp. dealer.

CAUTION

Be sure to perform operations as specified by the following instructions, and never touch any area not specified in the instructions.
Sudden movement of the machine may cause injury.

3

Maintenance

1. Display the [REPLACE WIPER] menu.



When the message shown in the figure appears, press **ENTER**.

2 Remove any media.

3 Press **MENU**.



Press **▼** several times until the screen shown on the left appears.

Press **▶**, and then **▲**.



Press **▶**, and then **▼**.



Press **ENTER**.

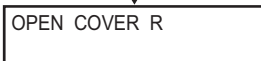
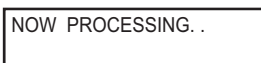

The screen shown in the figure appears.

2. Replace the wiper.

1 Open the cover R.

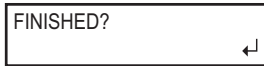
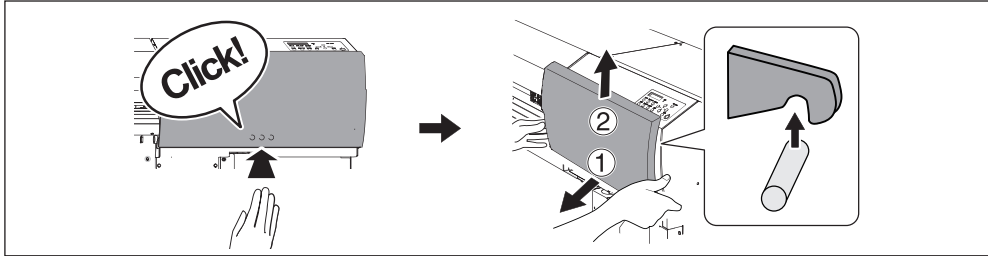

Preparations are complete when this screen appears.

2

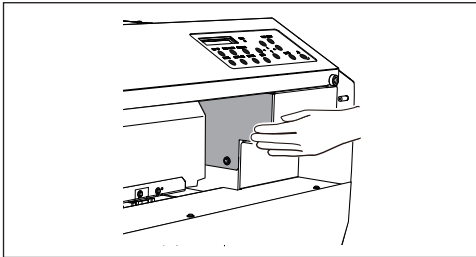

Touch the location shown in the figure to discharge any static electricity.

3

Replace the first wiper.

Detaching old wiper

Pull up and out

Detach the hook
Hitching the tweezers to the hole on the wiper makes the removal easier.

Point

Shine a flashlight on the area if it is too dark to see.

Attaching new wiper

Place the inclined end on the back side.
If the wiper is placed inversely, the proper cleaning becomes impossible.

Attach the hook.
Make sure to attach the hook. Otherwise it causes dot-drop out or else.

4 Press **ENTER**.

5 **CLOSE COVER R**

Close the cover R.

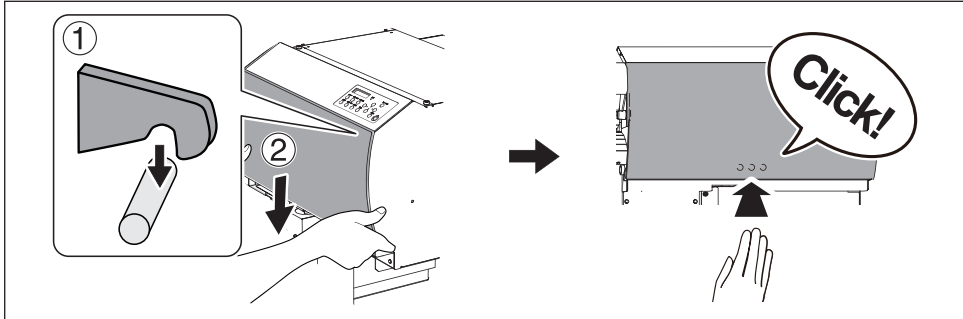

6 **OPEN COVER R**

Open the cover R.

FINISHED?

Preparations are complete when this screen appears.

7 **Clean the second wiper.**

The replacement procedure is same as the one for the first wiper. Refer to the illustration shown in step 3.

3. Quit the [REPLACE WIPER] menu.

1 Press **ENTER**.

2 **CLOSE COVER R**

Close the cover R.

MAINTENANCE ◀▶
REPLACE WIPER ↵

After the process to quit the wiper replacement menu, the screen shown in the figure appears.

3 Press **MENU** **◀** in this order to go back to the original screen.

4. Perform a printing test to verify the results of the procedure.

Perform a printing test to check the result.

☞ P. 51, "Printing Tests and Normal Cleaning"

Replacing the Felt Wipers

The felt wiper is the part used for cleaning of the print heads. When such the screen is displayed on the display screen, it is the time for replacement. There are two felt wipers. Replace both felt wipers with new ones.



Regarding the purchase of the felt wiper, contact your authorized Roland DG Corp. dealer.

⚠ CAUTION Be sure to perform operations as specified by these instructions, and never touch any area not specified in the instructions. Sudden movement of the machine may cause injury.

1. Display the [REPLACE FELT] menu.



When the message shown in the figure appears, press **ENTER**.

2 Remove any media.

3 Press **MENU**.



Press **▼** several times until the screen shown on the left appears. Press **▶**, and then **▲**.



Press **▶**. Press **▼** twice.



Press **ENTER**.

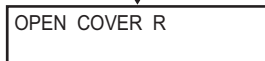

The Screen shown in the figure appears.

2. Replace the felt wiper.

1 Open the cover R.

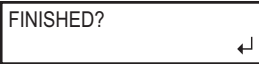
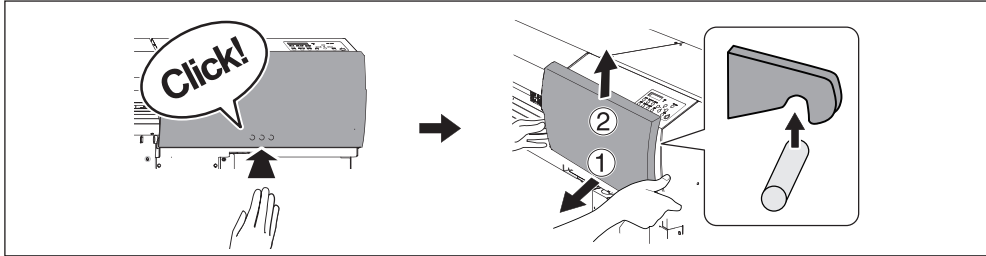

Preparations are complete when this screen appears.

2

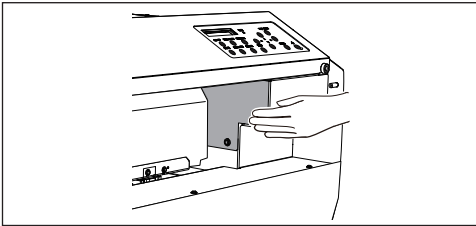

Touch the location shown in the figure to discharge any static electricity.

3 Open the front cover.

4 Clean the first felt wiper.

Detaching old felt wiper

Hook Tweezers (included part)

Pull up and out

Detach the hook
Hitching the tweezers to the hole on the wiper makes the removal easier.

Point

Shine a flashlight on the area if it is too dark to see.

Attaching new felt wiper

Hook

Attach the hook.
Make sure to attach the hook. Otherwise it cases dot-drop out or else.

5 Close the front cover.

6 Press **ENTER**.

7 **CLOSE COVER R** Close the cover R.

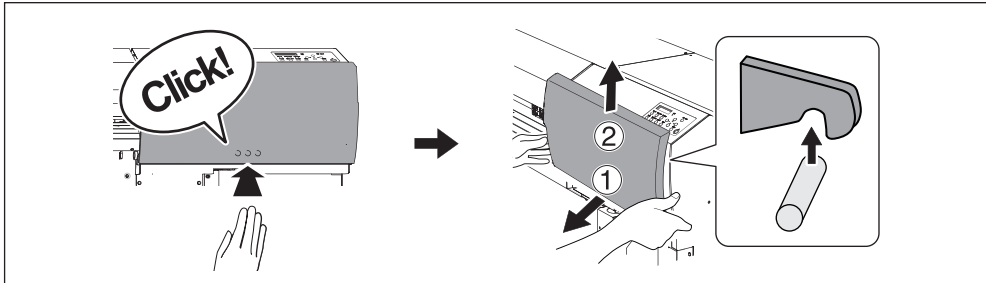

8 **OPEN COVER R** Open the cover R.

FINISHED? Preparations are complete when this screen appears.

9 Open the front cover.

10 Clean the second felt wiper.

The replacement procedure is same as the one for the first felt wiper. Refer to the illustration shown in step 4.

3. Quit the [REPLACE FELT] menu.

1 Close the front cover.

2 Press **ENTER**.

3 **CLOSE COVER R** Close the cover R.

MAINTENANCE **REPLACE WIPER** After the process to quit the wiper replacement menu, the screen shown in the figure appears.

4 Press **MENU** **←** in this order to go back to the original screen.

4. Perform a printing test to verify the results of the procedure.

Perform a printing test to check the result.

☞ P. 51, "Printing Tests and Normal Cleaning"

Replacing the Separating Knife

If the separating knife becomes dull, replace it with the included replacement knife.

⚠ CAUTION Be sure to perform operations as specified by these instructions, and never touch any area not specified in the instructions. Sudden movement of the machine may cause injury.

⚠ CAUTION Never touch the tip of the separating knife with your fingers. Doing so may result in injury.

1. Display the [REPLACE KNIFE] menu.

1 Remove any media.

2 Press **MENU**.



Press **▼** several times to display the screen shown on the left. Press **▶**, and then **▲**.



Press **▶**.



Press **▼** several times to display the screen shown on the left. Press **ENTER**.

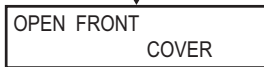
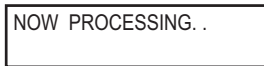

The cutting carriage moves to a location where knife replacement possible, and then the screen shown in the figure appears.

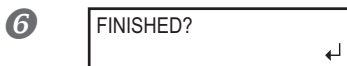

Open the front cover.
Preparations are complete when this screen appears.

2. Replace the separating knife.

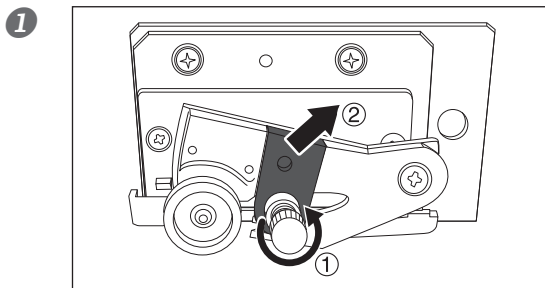

Remove the separating knife.

- 1 Loosen the screw until it slips out.
- 2 Grasp the screw portion, and slowly pull it out in the direction of the arrow. When doing this, do not pull it back toward you.

2

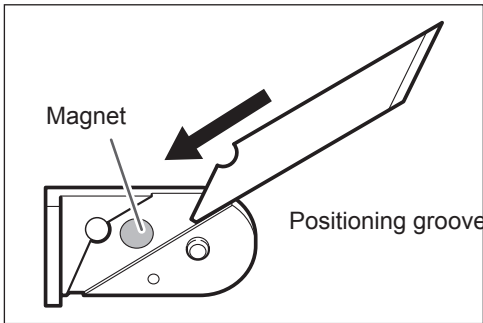

Install a new knife.

The knife is secured in place by the magnet.

3

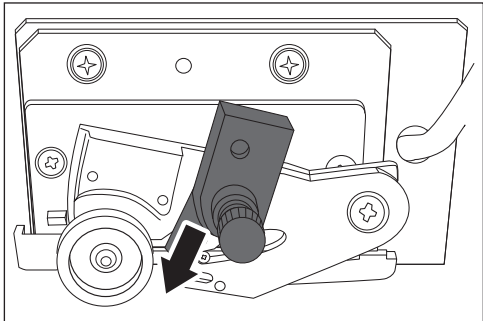

Slowly insert it into the groove.

4

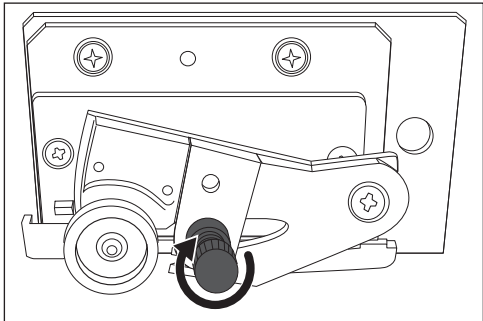

Tighten the screw.

Take care to ensure that the knife does not slip out of position at this time.

3 Maintenance

3. Quit the [REPLACE KNIFE] menu.

1

Close the front cover.

Press **ENTER**.

2

Press **MENU** **◀** in this order to go back to the original screen.

When Not in Use for a Prolonged Period

Keep Performing Maintenance

Switch On the Power Once a Month

Switch on the sub power once a month. When you turn on the power, the machine automatically performs some operations such as those to keep the print heads from drying out. Allowing the machine to stand completely unused for a prolonged period may damage the print heads, so be sure to switch on the power to perform these automatic operations.

Keep at a Constant Temperature and Relative Humidity

Even when the machine is not in use, keep it at a temperature of 5 to 40°C (41 to 104°F) and a relative humidity of 20 to 80% (with no condensation). Temperatures that are too high may degrade the ink and cause malfunction. Temperatures that are too low may cause the ink to freeze and damage the print heads.

3

Maintenance

Alarm Feature

PRESS THE POWER
KEY TO CLEAN

This feature is to remind you to switch on the sub power once a month. When the machine remains unused for about one month, this screen appears and a warning beep sounds. If this screen appears, switch on the sub power. When maintenance operations finish, switch off the sub power.

This feature operates when the printer's main power is turned on. Be sure to always switch on the printer's main power even if the printer is not used for a prolonged period.

Special maintenance

Draining Ink and Performing Internal Washing

Procedure

1 Press **MENU**.

2

MENU	◀◆
SUB MENU	▶

Press **▼** several times until the screen shown on the left appears.

Press **▶**.

Press **▲** twice.

3

SUB MENU	◀◆
INK CONTROL	▶

Press **▶**.

Press **▼** twice.

4

INK CONTROL	◀◆
HEAD WASH	▶↵

Press **ENTER** to enable the setting.

Description

This drains the ink inside the printer and washes the interior using cleaning cartridges as a preliminary for moving the printer or conducting maintenance. This work requires unused eight SOL INK cleaning cartridges designed for ECO-SOL MAX2. The screen displays information such as instructions to insert and remove cartridges. Follow these instructions to carry out the procedure. After finishing washing, the sub power is automatically switched off. You do not need to carry this out as part of your daily maintenance activities.

Draining Ink Remaining Inside the Machine

Procedure

1 Press **MENU**.

2

MENU	◀◆
SUB MENU	▶

Press **▼** several times until the screen shown on the left appears.

Press **▶**.

Press **▲** twice.

3

SUB MENU	◀◆
INK CONTROL	▶

Press **▶**, and then **▼**.

4

INK CONTROL	◀◆
PUMP UP	▶↵

Press **ENTER** to enable the setting.

Description

This removes ink inside the printer as a preliminary procedure for performing maintenance. The screen displays information such as instructions to insert and remove cartridges. Follow these instructions to carry out the procedure. After finishing the procedure, the sub power is automatically switched off. You do not need to carry this out as part of your daily maintenance activities.

Chapter 4

Part of Practice

Fully Utilizing Preset Function.....	90
Saving Various Settings as a Name Assigned Preset	90
Loading a Saved Preset	91
Automatic Loading of a Saved Preset When Media is Loaded ...	92
Fully Utilize the Media Heating System	93
What Is the Media Heating System?	93
Making the Temperature Setting for the Media Heating System ...	94
Control of Media Heating System during Preheating	95
Drying the Trailing Edge of the Printing Area on the Dryer.....	96
Setting the Drying Time after Printing.....	97
Using an Optional Dryer	97
Using a Blower-fan Unit.....	98
Fully Utilizing the Correction Function	99
Correcting for Misalignment in Bidirectional Printing.....	99
Correcting for Misalignment in Bidirectional Printing More Precisely...99	
Alleviating Horizontal Bands (feed correction function).....	100
Accommodating to the Types and Condition of Media.....	101
Adjusting the Print-Head Height to Match Media Thickness ...	101
Using Transparent Media	102
Printing Hard-to-dry Media	104
Using the Media Easy to be Winkled/Hard to be Fed.....	104
Speeding Up Output for Narrow Media	105
Expanding the Printing Area by Reducing the Margins	106
Preventing Soiling of the Media and Dot Drop-out	107
Using Sticky Media	108
Printing with Crop Marks.....	109
Printing with Crop Marks	109
Using Media Take-up System	110
Using Media Take-up System.....	110

Fully Utilizing Preset Function

Saving Various Settings as a Name Assigned Preset

Procedure

1 Press **MENU**.



Press **▼** to display the left figure.
Press **▶**, and then **▼**.



Press **▶**.

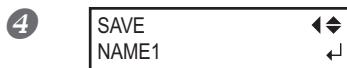

Press **▲** **▼** to select one of NAME1 through 8.
Press **ENTER** to enable the setting.
The present menu settings are saved.



Press **▲** **▼** to enter a character.
When a character is decided, press **▶**.

The characters you can enter are "A" through "Z," "0" through "9," and the "-" character. You can enter up to 15 characters, including spaces.



Press **▲** **▼** to enter a character.
Enter the following characters in the same way.
When entries are completed, press **ENTER** to enable the setting.

7 Press **MENU** **◀** in this order to go back to the original screen.

Description

Using the [PRESET] menu lets you easily change a wide variety of settings to optimize them for the media. Up to eight types of presets can be saved. You can assign a name to each one. Using media names for these may aid recognition and clarity. Making changes for each menu item every time you change the media can be troublesome. That's why it can be useful to save the menu-item settings optimized for an often-used type of media as a preset. The next time you use the media, you can change the menu-item settings to the optimal values for the media simply by loading the preset you saved. Menu items that can be saved in presets are listed below.

[PRE] (Preheater), [PRINT] (Print heater), [DRYER]	☞ P. 94, "Making the Temperature Setting for the Media Heating System"
[PREHEATING]	☞ P. 95, "Control of Media Heating System during Preheating"
[FEED FOR DRY]	☞ P. 96, "Drying the Trailing Edge of the Printing Area on the Dryer"
[DRYING TIME]	☞ P. 97, "Setting the Drying Time after Printing"
[ADJUST BI-DIR SIMPLE SETTING]	☞ P. 99, "Correcting for Misalignment in Bidirectional Printing"
[ADJUST BI-DIR DETAIL SETTING]	☞ P. 99, "Correcting for Misalignment in Bidirectional Printing More Precisely"
[CALIBRATION]	☞ P. 100, "Alleviating Horizontal Bands (feed correction function)"
[SHEET TYPE], [SHEET WIDTH], [SHEET POS].	☞ P. 102, "Using Transparent Media"
[SCAN INTERVAL]	☞ P. 104, "Printing Hard-to-dry Media"
[VACUUM POWER]	☞ P. 104, "Using the Media Easy to be Winkled/Hard to be Fed"
[FULL WIDTH S]	☞ P. 105, "Speeding Up Output for Narrow Media"
[SIDE MARGIN]	☞ P. 106, "Expanding the Printing Area by Reducing the Margins"
[MEDIA RELEASE]	☞ P. 108, "Using Sticky Media"

☞ P. 91, "Loading a Saved Preset"

Loading a Saved Preset

Procedure

1 Press **MENU**.

2

MENU	◀▶
PRESET	▶

Press **▼** to display the left figure.

Press **▶** twice.

3

LOAD	◀▶
NAME1	↵

Press **▲** **▼** to select a name to be called.

Press **ENTER** to enable the setting.

SETUP SHEET

The settings are changed and the screen shown in the figure appears.

Description

This loads a saved preset. You can select any one of eight types of presets. (When no names have been assigned, you select from among NAME1 through NAME8.) If you load a preset while **SET UP** is illuminated, **SET UP** goes dark. To start printing, press **SET UP** once more and redo the preparations for printing.

Automatic Loading of a Saved Preset When Media is Loaded

Procedure

1 Press **MENU**.

2  Press **▼** to display the left figure. Press **▶**, and then **▲**.

3  Press **▶**.

4  Press **▲** **▼** to select "ENABLE." Press **ENTER** to enable the setting.

5 Press **ENTER** **◀** in this order to go back to the original screen.

Description

Once "ENABLE" is selected, the screen for loading a preset is always displayed when the media is loaded. Follow the procedure given below to use the loaded preset.

How to Use The Loaded Preset

When you press **SET UP** at the end of the media loading process, the screen shown in the figure appears. When you press **ENTER**, the preset displayed in the screen is loaded. (Pressing **SET UP** before pressing **ENTER** performs setup with current settings without loading the preset).



The preset displayed in the screen is either the last loaded preset or last saved preset. You can select other presets by pressing **▲** and **▼**.

Fully Utilize the Media Heating System

What Is the Media Heating System?

This machine is equipped with a media heating system that warms the media. You use this mainly to improve ink adhesion and also dry the ink. You can adjust the temperature settings to match the type of media and the printing speed.

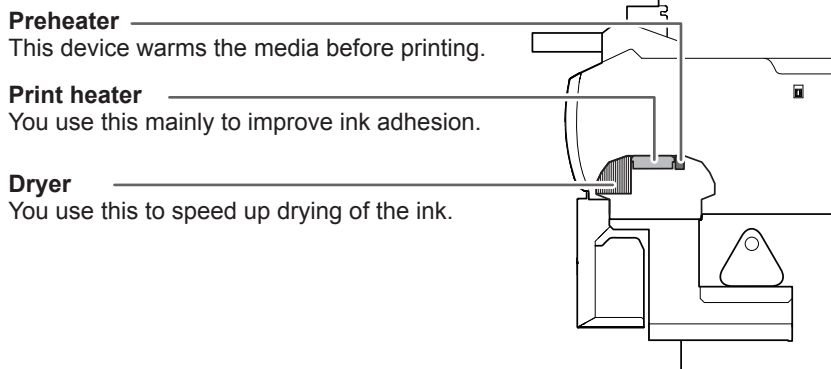

* By using an optional dryer, you can speed up drying of the ink more.

☞ P. 97, "Using an Optional Dryer"

⚠ WARNING

CAUTION: high temperatures

The platen and dryer become hot. Exercise caution to avoid fire or burns.

⚠ WARNING

Remove any loaded media or switch off the sub power when printing is not being performed.

The continued application of heat at a single location may cause fire or produce toxic gases.

⚠ WARNING

Never use media that cannot withstand the heat.

Doing so may result in fire or the release of toxic gases, or may degrade the media.

⚠ WARNING

Never use the platen or dryer for any purpose for which they are not intended, such as to dry clothing.

Doing so may cause overheating, resulting in fire or accident.

Use at an ambient temperature of 20 to 32°C (68 to 90°F).

If the machine is used at an ambient temperature lower than 20°C (68°F), then depending on the type or width of the media, wrinkling or temperature-caused unevenness may occur. If this happens, try lowering the temperature of the media heating system by about 2°C. To obtain stable printing results, however, the machine should be used at an ambient temperature of 20 to 32°C (68 to 90°F).

Making the Temperature Setting for the Media Heating System

Procedure

1 Press **HEATER**.

2

PRE	40	PRINT	40
DRY	50		

The present temperature is displayed.

Press **HEATER** a second time.

3

DRYER	50	↔
	50	▶ 50 ◀

Press **◀ ▶** to select the unit.

4

DRYER	50	↔
	50	▶ 55 ◀

Press **▲ ▼** to select a temperature.

You can set to "OFF."

Press **ENTER** to enable the setting.

5 Press **MENU ◀** in this order to go back to the original screen.

Estimate and Hint of Temperature Setting

The optimal temperature for the media heating system varies according to such factors as the type of media and differences in the print mode. Use the following as a general guide and adjust accordingly.

Preheater	Set this to a temperature that is the same as or lower than the temperature of the print heater. You use the preheater mainly to heat media gradually. This is because media becomes more likely to shrink or wrinkle if heated suddenly.
Print heater	You use this mainly to improve ink adhesion and inhibit smudging. If the ink forms lumps or smudges, raise the temperature. Note, however, that a temperature that is too high may degrade the media or cause it to wrinkle.
Dryer	When ink drying is poor, raise the temperature. Note, however, that a temperature that is too high may degrade the media or cause it to wrinkle.
The relationship between the print mode and temperature	The optimal temperature for the media heating system varies according to such factors as the type of media and differences in the print mode. If smudging or poor drying occur even after raising the temperature, try using a print mode of software RIP offering higher image quality. Conversely, when you want to use a faster print mode, raise the temperature.
Amount of ink	When you change the amount of ink using the settings for your software RIP, adjusting this may yield better results. If problems such as smudging persist even after raising the temperature, try reducing the amount of ink.
Other points to remember	When recommended settings for temperature, print mode, and other values are given as the use condition of your media, use the suggested settings.

Examples of Preset Temperatures

Media	Temperature
Type: Scrim banner (PVC) Thickness: 300 to 400 µm (12 to 16 mil)	Preheater: 40°C (104°F) Print heater: 40°C (104°F) Dryer: 50°C (122°F)
Type: Marking film (PVC, with adhesive) Thickness: 60 to 100 µm (2.5 to 4 mil, not including backing paper)	

- These are only rough estimates. Make adjustments to match the media you're using.
- Using the media heating system does not necessarily make it possible to apply ink to every kind of media. Be sure to test in advance.
- Results may vary greatly depending on the print mode and other factors. Make settings suited to the media.
- When suggested settings for temperature, print mode, and other values are given, use the suggested settings.

Description

By default setting, simply switching on the power does not make the media heating system warm up to the preset temperature. The temperature rises until preset temperature when the media is loaded correctly and **SET UP** lights up. You can also make this setting on the software RIP. When you have made the setting on the software RIP, the software RIP's setting is used.

NOTE: Depending on the usage environment, the temperature of the print heater or dryer may become higher than the preset temperature, but this does not represent a problem.

Default Setting

[PRE]: 40°C (104°F)
[PRINT]: 40°C (104°F)
[DRY]: 50°C (122°F)

Control of Media Heating System during Preheating

Note: Preheating: State that the main power and the sub power are switched on and **SET UP** is not lighted (state that media setup is not completed).

Procedure

1 Hold down **MENU** and press **HEATER**.

2  Press   in this order to display the left figure.
Press .

- 3

PREHEATING	◀◆
30°C	▶ MENU

 Press to select setting.
 Press to enable the setting.

MENU	The system performs heating to the preset temperature at all times, without lowering the temperature during preheating.
30°C	The system keeps 30°C during preheating.
OFF	The system switches the media heating system off during preheating.

- 4 Press in this order to go back to the original screen.

Default Setting

[PREHEATING]: 30°C

Drying the Trailing Edge of the Printing Area on the Dryer

Procedure

- 1 Hold down and press .
- 2

HEATER MENU	◀◆
FEED FOR DRY	▶

 Press to display the left figure.
 Press .
- 3

FEED FOR DRY	◀◆
DISABLE	▶ ENABLE

 Press to select "ENABLE."
 Press to enable the setting.
- 4 Press in this order to go back to the original screen.

Description

- "ENABLE" : media feed is performed until the trailing edge of the printing area is positioned on the dryer. A margin from the print end position to the subsequent print start position is fixed at 200 mm. The margin set on the computer is ignored.
☞ P. 97, "Using an Optional Dryer"
- "DISABLE" : media feed stops simultaneously when printing ends. This means that the trailing edge of the printing area is not fed to the dryer unless you continue with a subsequent printing operation.

Default Setting

[FEED FOR DRY]: DISABLE

Setting the Drying Time after Printing

Procedure

- 1 Hold down **MENU** and press **HEATER**.
- 2 Press **▶**.
- 3

HEATER MENU	◀◆
DRYING TIME	▶

 Press **▲** to display the screen shown on the left.
Press **▶**.
- 4

DRYING TIME	◀◆
0min	▶ 10min
	↵

 Press **▲** **▼** to select the interval.
Press **ENTER** to enable the setting.
- 5 Press **MENU** **◀** in this order to go back to the original screen.

Description

Set the interval after the 1st page is printed. The next operation is not started until the set time passes. **PAUSE** is lighting during the interval. When pressing **PAUSE** while **PAUSE** is lighting, the interval is finished and the next operation is started. When holding on **SET UP** while **PAUSE** is lighting, output is canceled. You can also make this setting on the software RIP. When you have made the setting on the software RIP, the software RIP's setting is used.

Default Setting

[DRYING TIME]: 0 min

Using an Optional Dryer

Procedure

- 1 Hold down **MENU** and press **HEATER**.
- 2 Press **▶**.
- 3

HEATER MENU	◀◆
OPTION DRYER	▶

 Press **▼** several times to display the screen shown on the left.
Press **▶**.
- 4

OPTION DRYER	◀◆
DISABLE	▶ ENABLE
	↵

 Press **▲** **▼** to select "ENABLE."
Press **ENTER** to enable the setting.
- 5 Press **MENU** **◀** in this order to go back to the original screen.

Description

This switches the optional dryer "ENABLE" or "DISABLE." When using an optional dryer, set [OPTION DRYER] to "ENABLE." And you can speed up drying of the ink more. Contact your authorized Roland DG Corp. dealer for recommended dryer models. For the details of how to use an optional dryer, refer to the documentation for the dryer you're using.

Default Setting

[OPTION DRYER]: DISABLE

Using a Blower-fan Unit

Procedure

- 1 Hold down **MENU** and press **HEATER**.
- 2 Press **▶**.
- 3

HEATER MENU	◀▶
BROWER FAN	▶

 Press **▼** several times to display the screen shown on the left.
Press **▶**.
- 4

BROWER FAN	◀▶
DISABLE ▶ ENABLE	↵

 Press **▲** **▼** to select "ENABLE."
Press **ENTER** to enable the setting.
- 5 Press **MENU** **◀** in this order to go back to the original screen.

Description

This switches the optional blower-fan unit "ENABLE" or "DISABLE." When using an blower-fan unit, select "ENABLE." And you can speed up drying of the ink more. Contact your authorized Roland DG Corp. dealer for recommended blower-fan unit models. For the details of how to use a blower-fan unit, refer to the documentation for the blower-fan unit you are using.

Default Setting

[BLOWER FAN]: DISABLE

Fully Utilizing the Correction Function

Correcting for Misalignment in Bidirectional Printing

Procedure

1 Press **MENU**.



Press **▼** several times to display the screen shown on the left.

Press **▶**.



Press **ENTER**.

A test pattern is printed.

When printing is completed, press **▼** **▶** in this order.



Press **▲** **▼** to select a correction value.

Press **ENTER** to enable the setting.

To decide a correction value

Choose the value that produces the least misalignment of 2 lines.

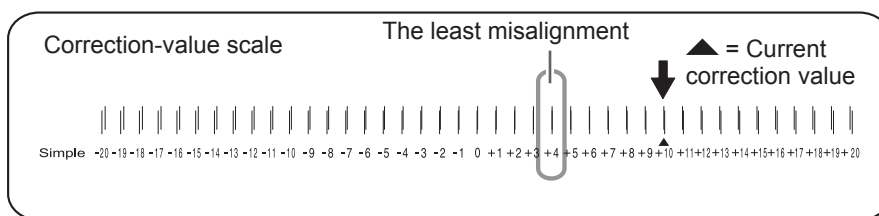

5 Press **MENU** **◀** in this order to go back to the original screen.

Description

This machine prints by the bidirectional mode (in which the print heads perform printing during both their outbound pass and return pass). This printing method is called "Bidirectional Printing." This method offers the advantage of being able to shorten output times, but subtle misalignment occurs during the outbound and return passes. The procedure to correct this and eliminate misalignment is "Bidirectional Correction." This misalignment varies according to the print-head height and the thickness of the media, so we recommend performing correction to match the media you're using.



Correcting for Misalignment in Bidirectional Printing More Precisely

When further correction is required, such as when adjustment made using [SIMPLE SETTING] does not enhance printing, use [DETAIL SETTING] to make corrections.

For information on operations, refer to P. 42, "Performing the Initial Adjustment (Correcting for Misalignment in Bidirectional Printing More Precisely)"

Alleviating Horizontal Bands (feed correction function)

Procedure

- 1 When the roll media is used, check that no sagging is found on the media.
- 2 Press **MENU**.
- 3  Press **▼** several times to display the screen shown on the left.
Press **▶**.
- 4  Press **ENTER**.
A test pattern is printed.
When printing is completed, press **▼** **▶** in this order.
- 5  Press **▲** **▼** to select a correction value.
Press **ENTER** to enable the setting.

To decide a correction value

Select the value to make the upper/lower rectangular gap and overlap smallest.

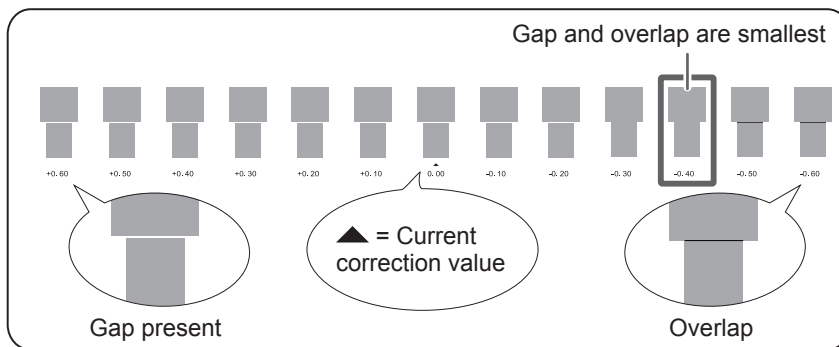

- 6 Press **MENU** **◀** in this order to go back to the original screen.

Description

The movement distance of media experiences subtle changes due to the thickness of the media and the temperature of the media heating system. When the movement distance becomes discrepant, horizontal stripes are more likely to occur during printing. We recommend performing correction to match the media you're using and the media heating system. Repeat the process of printing a test pattern and entering a correction value several times to find the optimal value. You can also make this setting on the software RIP computer (by, for example, choosing the media type in the software RIP you are using). When you have made the setting on the computer, the computer's setting is used and the printer's setting is ignored.

Default Setting

[SETTING]: 0.00%

Accommodating to the Types and Condition of Media

Adjusting the Print-Head Height to Match Media Thickness

Procedure

1 Press **MENU**.

2 

Press  several times to display the screen shown on the left.

Press .

3 

When the left figure is displayed, open the front cover.

4 Move the height-adjustment lever to adjust the print-head height.

Moving the lever to "HIGH" makes a warning beep sound twice. Moving it to "LOW" makes the warning beep sound once.

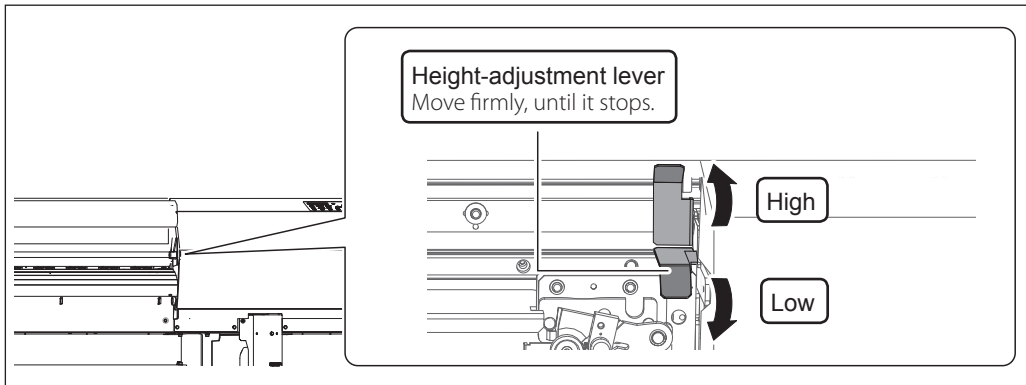

5 

Close the front cover.

The print-head carriage moves to the original position, and then the screen shown in the figure appears.

6 Press **MENU**  in this order to go back to the original screen.

Description

Depending on the media, media may wrinkle or come loose from the platen during printing, increasing the chance of contact with the print heads. When you are using such media, adjust the [HEAD HEIGHT] to "HIGH." Printing quality when the [HEAD HEIGHT] is set to "HIGH" may be coarser or otherwise lower than when set to "LOW." If this happens, refer to the pages indicated below.

☞ P. 42, "Performing the Initial Adjustment (Correcting for Misalignment in Bidirectional Printing More Precisely)"

☞ P. 99, "Correcting for Misalignment in Bidirectional Printing"

☞ P. 110, "Using Media Take-up System"

Using Transparent Media

1. Set the media type to "CLEAR."

1 Press **MENU**.



Press **▼** several times to display the screen shown on the left.

Press **▶** twice.

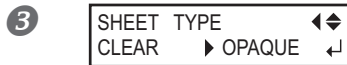

Press **▲** **▼** to select "CLEAR."

Press **ENTER** to enable the setting.

2. Make the setting for the media width.



Press **◀** to display the screen shown on the left.

Press **▼**.



Press **▶**.



Press **▲** **▼** to enter the media width.

Press **ENTER** to enable the setting.

4 Press **MENU** **◀** in this order to go back to the original screen.

3. Load transparent media to the printer.

Refer to P. 32, "Loading Media"

4. Make the setting for the location of the right edge of the media.

1 Press **MENU**.



Press **▼** several times to display the screen shown on the left.

Press **▶**.

Press **▼** twice.



Press **▶**.

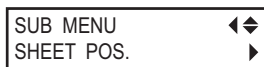

The print heads are moved to the specified position, and the screen shown on the left is displayed.

4 Open the front cover.

5

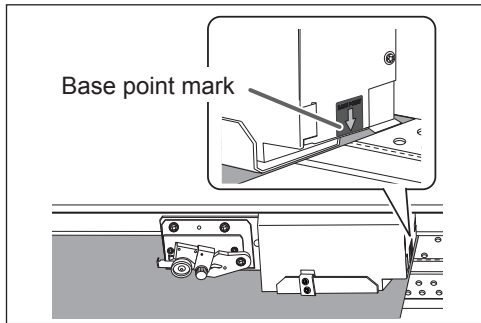

Move the print heads (base point mark) to the right end of the media pressing .

The position indicated by the arrow of the base point mark is set as the location of the right edge of the media.

If a fixed period of time passes while the setting is in process, the menu is forcefully terminated.

If a fixed period of time passes while the setting is in process, the menu is forcefully terminated and the print heads are returned to the home position to prevent them from drying out. In that case, perform the step **4**. again.

To cancel ongoing setting for the location of right edge of media

1 Close the front cover.



Press  to display the left figure.

3 Press .

The print heads return to the standby position (inside the cover R).

6 After positioning, close the front cover.

Press  to enable the setting.

Description

For transparent media, the width and position cannot be automatically detected. Therefore, [SHEET TYPE] must be set to "CLEAR" before the width and attaching position are set manually.

When [SHEETTYPE] is set to "CLEAR," printing does not stop if the media runs out while printing is in progress. If media runs out while printing is in progress, immediately press  to quit printing. Otherwise, there is a chance that the platen or the like may become soiled by ink or that ink may get inside and damage the machine.

Default Setting

[SHEET TYPE]: OPAQUE
[SHEET WIDTH]: 1625 mm

Printing Hard-to-dry Media

Procedure

1 Press **MENU**.



Press **▼** several times to display the screen shown on the left.
Press **▶**.



Press **▼** several times to display the screen shown on the left.
Press **▶**.



Press **▲** **▼** to select a value.
Larger values produce progressively slower movement of the media, enabling you to extend the drying time accordingly.
Press **ENTER** to enable the setting.

5 Press **MENU** **◀** in this order to go back to the original screen.

Description

You use this when ink dries poorly even when the media heating system is used. You can also make this setting on the software RIP. When you have made the setting on the software RIP, the software RIP's setting is used and the printer's setting is ignored.

Default Setting

[SCAN INTERVAL]: OFF

Using the Media Easy to be Winkled/Hard to be Fed

Procedure

1 Press **MENU**.



Press **▼** several times to display the screen shown on the left.
Press **▶**.



Press **▼** several times to display the screen shown on the left.
Press **▶**.

- 4 Press to select a value.
Press to enable the setting.

0 to 100%	A larger value produces a larger suction force. For the media easy to be loose due to warping or wrinkling, increase of the suction force may help correct the problem. When the media is flimsy and cannot move smoothly, reduction of the suction force may correct such the problem.
AUTO	The suction force is automatically adjusted to the optimal level for the media width.

- 5 Press in this order to go back to the original screen.

Description

The platen uses suction to grip the media and keep it stable. The suction force can be adjusted corresponding to the mature and condition of the media. You can also make this setting on the software RIP. When you have made the setting on the software RIP, the RIP's setting is used and the printer's setting is ignored.

Default Setting

[VACUUM POWER]: AUTO

Speeding Up Output for Narrow Media

Procedure

- 1 Press .



- 2 Press several times to display the screen shown on the left.
Press .

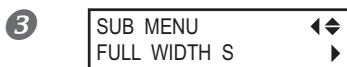

- 3 Press several times to display the screen shown on the left.
Press .



- 4 Press to select an item.
Press to enable the setting.

SHEET	"SHEET" matches the range of the print heads movement to the width of the media.
OFF	"OFF" matches the range of the print heads movement to the output data. Movement is limited to the minimum amount necessary, and this can be expected to yield the fastest output. Note, however, that because the speed of media movement is no longer constant, colors may be uneven.
FULL	This makes the speed of media movement constant at all times and produces the most stable printing result.

- 5 Press   in this order to go back to the original screen.

Description

This shortens output time by reducing the width of the print heads movement to the minimum necessary. This is effective when the width of the media or the output data is narrow.

Default Setting

[FULL WIDTH S]: FULL

Expanding the Printing Area by Reducing the Margins

Procedure

- 1 Press .



Press  several times to display the screen shown on the left.
Press .



Press  several times to display the screen shown on the left.
Press .



Press   to select [5mm].
Press  to enable the setting.

- 5 Press   in this order to go back to the original screen.

Description

This makes the setting for distance from the left or right media clamp to the corresponding left or right edge of the printing area. You can select either "5 mm", "10 mm," or "25 mm." Setting this to "5 mm" lets you expand the printing area.

☞ P. 138, "Maximum Area and Margins"

Note, however, that when you're using transparent media, setting this to "5 mm" may result in printing on top of the media clamps.

Default Setting

[SIDE MARGIN]: 10 mm

Preventing Soiling of the Media and Dot Drop-out

Procedure

- 1 Press **MENU**.
- 2

MENU	◀◆
SUB MENU	▶

 Press **▼** several times to display the screen shown on the left.
Press **▶**.
- 3

SUB MENU	◀◆
PERIODIC CL.	▶

 Press **▼** several times to display the screen shown on the left.
Press **▶**.
- 4

PERIODIC CL.	◀◆
NONE ▶ 10min	◀

 Press **▲** **▼** to select an item.
Press **ENTER** to enable the setting.

PAGE	Automatic cleaning is performed every time before printing starts.
10 to 990 min	Automatic cleaning is performed when the cumulative printing time reaches the value you set here.
NONE	Automatic cleaning is not performed.

- 5 Press **MENU** **◀** in this order to go back to the original screen.

Description

In the following cases, ink tends to collect on the surface of the print heads. Under some conditions, this ink may be transferred to the media or cause dot drop-out. Use this feature at such times.

- When you use media prone to buildup of static charge.
- When the ambient temperature is low.
- When the print-head height is set to "HIGH."

Selecting "PAGE" or a value from "10 min" to "990 min," the ink buildup is removed before or during printing while printing is performed. Note, however, that using "PAGE" or a value from "10 min" to "990 min," results in longer printing times.

Default Setting

[PERIODIC CL.]: NONE

Using Sticky Media

Procedure

1 Press **MENU**.

2

MENU	◀◆
SUB MENU	▶

Press **▼** several times to display the screen shown on the left.

Press **▶**.

3

SUB MENU	◀◆
MEDIA RELEASE	▶

Press **▼** several times to display the screen shown on the left.

Press **▶**.

4

MEDIA RELEASE	◀◆
DISABLE ▶ ENABLE	↵

Press **▲** **▼** to select "ENABLE."

Press **ENTER** to enable the setting.

5 Press **MENU** **◀** in this order to go back to the original screen.

Description

Some types of media may tend to stick to the platen. Starting printing with the media sticking to the platen may make normal media feed impossible and cause the media to jam. When you're using such media, set the [MEDIA RELEASE] menu item to "ENABLE." This peels off the media if sticking before starting printing. Note, however, that media feed may be unstable when printing is performed after executing this operation. Leave this menu item set to "DISABLE" unless you specifically need to change it.

Default Setting

[MEDIA RELEASE]: DISABLE

Printing with Crop Marks

Printing with Crop Marks

Use your software RIP to make the settings for printing crop marks. For information on how to make the setting, refer to the documentation for the software RIP you're using.

IMPORTANT!

Alignment marks and symbols drawn using a graphics program cannot be used as crop marks.

The crop marks are printed as shown in the figure.

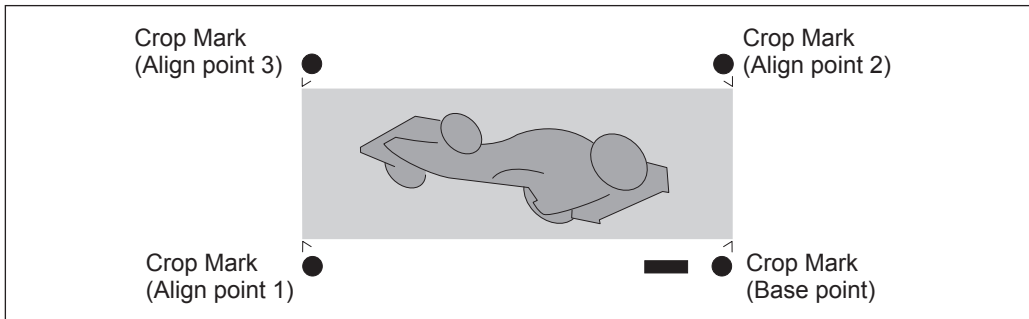

Using Media Take-up System

Using Media Take-up System

Note: The media take-up system (hereinafter called take-up system) is optional part.

Note: For information on how to assemble and install the take-up system, refer to the user's manual of the take-up system.

Chapter 5

To Administrators

Output Operation Management	112
Printing a System Report.....	112
Determining What Happens When Ink Runs Out.....	112
Displaying the Amount of Media Remaining.....	113
Making Sure to Verify the Setting for the Amount Remaining Every Time the Media Is Changed	114
Printing the Amount of Remaining Media	115
System Management of Printer	116
Setting for the Menu Language and the Units of Measurement... ..	116
Setting the Interval until Activation of the Sleep Mode (Power Saving Function)	116
Viewing Information about the System of This Machine.....	117
Returning All Settings to Their Initial Values	118

Output Operation Management

Printing a System Report

This prints system information, including a list of setting values.

Procedure

- 1 Press **MENU**.
- 2

MENU	◀◆
SUB MENU	▶

 Press **▼** several times to display the screen shown on the left.
Press **▶**.
- 3

SUB MENU	◀◆
SYSTEM REPORT	▶↵

 Press **▼** several times to display the screen shown on the left.
Press **ENTER**.
Start printing.
- 4 Press **MENU** **◀** in this order to go back to the original screen.

Determining What Happens When Ink Runs Out

This lets you change, according to your purpose, the operation that takes place when an ink cartridge is empty.

Procedure

- 1 Press **MENU**.
- 2

MENU	◀◆
SUB MENU	▶

 Press **▼** several times to display the screen shown on the left.
Press **▶**.
Press **▲** twice.
- 3

SUB MENU	◀◆
INK CONTROL	▶

 Press **▶** twice.
- 4

EMPTY MODE	◀◆
STOP ▶ CONT.	▶↵

 Press **▲** **▼** to select.
Press **ENTER** to enable the setting.

STOP	Printing pauses immediately when a cartridge becomes empty.
CONT. (continue)	Printing does not stop when a cartridge becomes empty. When a cartridge becomes empty, a warning beep sounds.

- 5 Press **MENU** **◀** in this order to go back to the original screen.

Description

When "STOP" is selected, printing pauses and so colors may be uneven. Ensure a sufficient amount of remaining ink before you begin printing. When "CONT." is selected, printing does not stop even if ink runs out completely. To replace the cartridge, wait until printing ends or press **PAUSE** to pause printing.

Default Setting

[EMPTY MODE]: STOP

Displaying the Amount of Media Remaining

You can display how much of the media in use is left. First, you set the amount of media remaining, the amount remaining is displayed at the top menu until it reaches zero.

Procedure

1 Press **MENU**.

2 

Press **▲** to display the left figure.
Press **▶**, and then **▼**.

3 

Press **▶**.

4 

Press **▲** **▼** to set the current amount of media remaining.
Press **ENTER** to enable the setting.

5 

Press **MENU** **◀** in this order to go back to the original screen.

This display is updated.



If setup has not been performed, the set value flashes.

Description

If you cancel the setup such as by removing the media or raising the loading lever, the amount remaining at that time flashes on the screen. Because the amount of media remaining is not updated automatically when you change the media, redo the setting whenever you change the media. You can also make the setting display this menu automatically whenever you change the media. See the next section, "Making Sure to Verify the Setting for the Amount Remaining Every Time the Media Is Changed."

Note: The remaining amount that is displayed is only an estimate, and its accuracy is not assured.

Making Sure to Verify the Setting for the Amount Remaining Every Time the Media Is Changed

Set to display  every time when a media is changed.

Procedure

1 Press .

2 

Press  to display the screen shown on the left.

Press .

Press  twice.

3 

Press .

4 

Press   to select "ENABLE".

Press  to enable the setting.

If you set to "ENABLE," you must set the [SHEET TYPE] menu to "OPAQUE."
 ⇨ P. 102, "Using Transparent Media"

5 Press   in this order to go back to the original screen.

Description

Setting this menu to "ENABLE" can keep you from forgetting to redo the setting when you change the media. Be sure, however, also to set the [SHEET TYPE] menu (refer to P. 102, "Using Transparent Media") to "OPAQUE." When [SHEET TYPE] is set to "CLEAR," [SHEET REMAIN] is not displayed automatically.



Default Setting

[AUTO DISPLAY]: DISABLE

Printing the Amount of Remaining Media

This prints the amount of media remaining that is displayed at the top menu.

Procedure

- 1 Press **MENU**.
- 2  Press **▲** to display the screen shown on the left.
Press **▶**.
- 3  Press **ENTER**.
Start printing.
- 4 Press **MENU** **◀** in this order to go back to the original screen.

Description

You use this when you want to make a record of the remaining length of the media now in use. Printing the amount of media remaining before you change the media enables you to refer to the printed record and use the value to make the setting for the remaining amount the next time you use the media.

Note, however, that continuing by performing the next output starts the output on top of the portion where the amount of remaining media is printed. After printing the amount remaining, then before you perform the next output operation, we recommend cutting off the media.

System Management of Printer

Setting for the Menu Language and the Units of Measurement

This sets the language and units of measurement displayed on the display screen of the operation panel.

Procedure

- 1 Hold down **MENU** and switch on the sub power.
- 2

MENU LANGUAGE	↕
ENGLISH	↵

 Use **▲** **▼** to select the display (menu) language.
Press **ENTER** to enable the setting.
- 3

LENGTH UNIT	↕
mm ▶ INCH	↵

 Use **▲** **▼** to select the measurement unit for length.
Press **ENTER** to enable the setting.
- 4

TEMP. UNIT	↕
°C ▶ °F	↵

 Use **▲** **▼** to select to the measurement unit for temperature.
Press **ENTER** to enable the setting.

Default Setting

[MENU LANGUAGE]: ENGLISH

[LENGTH UNIT]: mm

[TEMP. UNIT]: °C

Setting the Interval until Activation of the Sleep Mode (Power Saving Function)

Procedure

- 1 Press **MENU**.
- 2

MENU	↕
SUB MENU	▶

 Press **▼** several times to display the screen shown on the left.
Press **▶**.
- 3

SUB MENU	↕
SLEEP	▶

 Press **▲** several times to display the screen shown on the left.
Press **▶** twice.
- 4

INTERVAL	↕
30 min ▶ 15 min	↵

 Use **▲** **▼** to make the setting.
Press **ENTER** to enable the setting.
- 5 Press **MENU** **◀** in this order to go back to the original screen.

Default Setting

[INTERVAL]: 30 min

Viewing Information about the System of This Machine

Note: For information on how to set up a network, refer to "Setup Guide."

Procedure

1 Press **MENU**.



Press **▲** several times to display the screen shown on the left.

You can view the following information.

[MODEL]: Model name

[SERIAL NO.]: Serial number

[INK]: Ink type

[FIRMWARE]: Firmware version

[NETWORK]: Network setting such as IP address

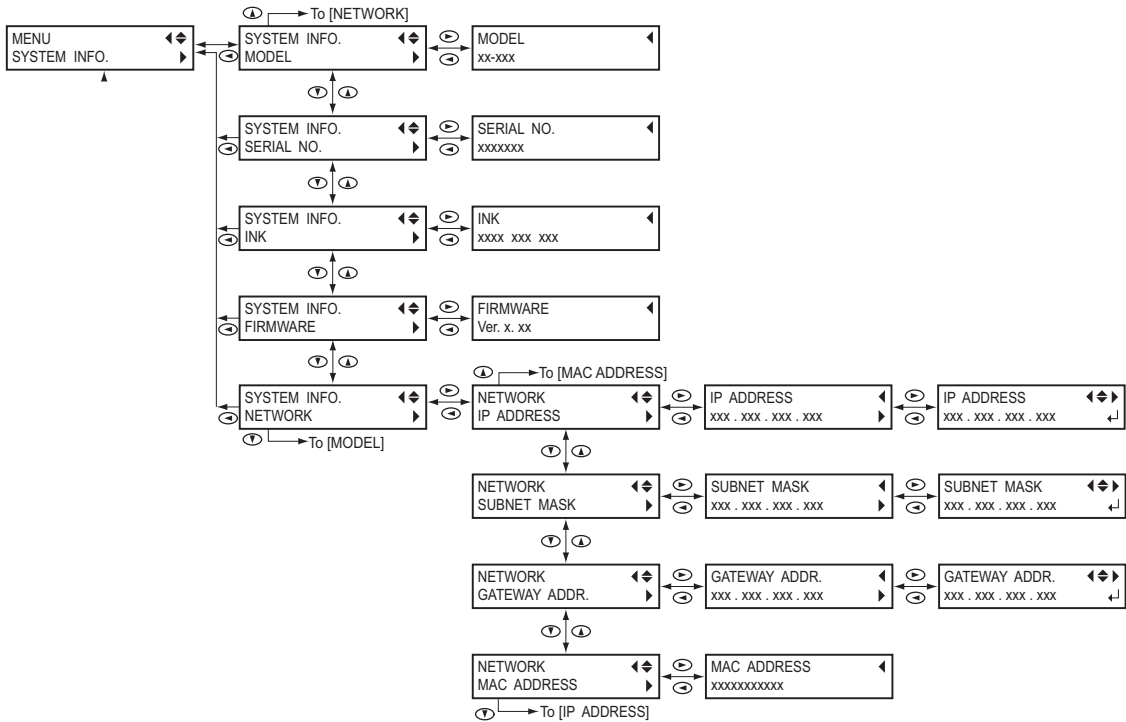

Returning All Settings to Their Initial Values

This menu returns all settings to the same as their factory defaults. However, the settings for [MENU LANGUAGE], [LENGTH UNIT], and [TEMP. UNIT] are not returned to the factory defaults.

Procedure

1 Press **MENU**.

2

MENU	◀◆
SUB MENU	▶

Press **▼** several times to display the screen shown on the left.

Press **▶**.

3

SUB MENU	◀◆
FACTORY DEFAULT	↵

Press **▼** several times to display the screen shown on the left.

Press **ENTER** to execute.

Chapter 6

Read This Chapter

Whenever You Face a Problem. (FAQ)

Printer Does Not Start Up!	120
The Printer Unit Doesn't Run.....	120
The Media Heating System Doesn't Warm Up	121
Cannot Cut Off The Media.....	122
Attractive Printing is Impossible	123
Printed Results Are Coarse or Contain Horizontal Stripes	123
Colors Are Unstable or Uneven.....	124
The Media Becomes Soiled When Printed.....	125
Media Jam Occurs!.....	126
The Media Jams	126
Media Feed is Not Smooth	127
Media Wrinkles or Shrinks.....	127
Media Feed Is Not Straight.....	128
Media Feed Is Not Smooth.....	128
Print Heads Stop Moving. Why?	129
What to Do First.....	129
If the Print Heads Still Do Not Move	129
A Message Appears	131
An Error Message Appears.....	133

Printer Does Not Start Up!

The Printer Unit Doesn't Run

Is the power switched on?

Switch on the printer's main power, then press the sub power switch and make sure the sub power switch lights up.

☞ P. 31, "Switch On!"

Is **SET UP** illuminated?

Output is not performed when **SET UP** is not illuminated. Down the loading lever, close the front cover, and press **SET UP**.

☞ P. 53, "Getting Ready to Receive Data from a Computer"

Is the front cover open?

Close front cover, cover L and cover R.

Is the top menu displayed?

Top menu



W 1200 m

If the top menu isn't displayed, output doesn't start even when data is sent from the computer. To go to the top menu, press **MENU**, then press **◀**.

☞ P. 53, "Getting Ready to Receive Data from a Computer"

Is **PAUSE** illuminated?

When **PAUSE** lights up, operation is paused. To resume, press **PAUSE**. **PAUSE** goes dark and outputting resumes.

☞ P. 56, "Pausing and Canceling Output"

Has ink run out?



1 _ 2 ■ 3 ■ 4 ■
5 ■ 6 ■ 7 ■ 8 ■

When printing data is sent while the screen shown in the figure is displayed, a message appears and a warning beep sounds. At the same time, operation pauses. When the ink cartridge is replaced with a new one, printing starts.

☞ P. 61, "How to Replace Ink Cartridges"

☞ P. 112, "Determining What Happens When Ink Runs Out"

Is a message displayed on the screen?

- ☞ P. 131, "A Message Appears"
- ☞ P. 133, "An Error Message Appears"

Is the cable connected?

Connect the cable securely.

- ☞ "Setup Guide"

Is the network routing appropriate?

Confirm whether the network routing is appropriate. Try connecting the computer and the machine to the same hub, or connecting them directly using a crossover cable. If this makes it possible to perform output, it means the problem is in the network itself.

Are the network settings correct?

If the cable connections are secure and no problem is found in the network itself, make sure that the IP address and other such settings are appropriate. The settings on both the machine and the computer must be appropriate. Redo the settings, checking to ensure that the IP address doesn't conflict with the IP address for another device on the network, that the port setting for the software RIP specifies the IP address set on the machine, that the settings have no typing errors, and for other such problems.

- ☞ "Setup Guide"
- ☞ P. 117, "Viewing Information about the System of This Machine"

Did the software RIP end abnormally?

Make sure the software RIP is running correctly, then switch the sub power switch off and back on.

- ☞ "Roland VersaWorks Quick Start Guide"

The Media Heating System Doesn't Warm Up

Is media loaded?

The media heating system does not warm up to the preset temperature when  is dark (by default). Load media and wait for the machine to warm up.

- ☞ P. 93, "Fully Utilize the Media Heating System"

Is the temperature of the room too low?

Use the machine in an environment where the temperature is 20 to 32°C (68 to 90°F).

Cannot Cut Off The Media

Is the separating knife mounted?

If the separating knife is not mounted, you cannot cut off the media.

☞ P. 84, "Replacing the Separating Knife"

Are the cut rail mounted?

If the cut rail is not mounted, you cannot cut off the media. Remove the cut rail before performing the manual cleaning. If the cut rail is not installed, remove the cover L, and then install the cut rail by following the step 4 in P. 75, "Reattach cover L, cover R, and quit the manual cleaning menu." After installing the cut rail, be sure to install the cover L again.

Attractive Printing is Impossible

Printed Results Are Coarse or Contain Horizontal Stripes

Does the print heads show dot drop-out?

Carry out a printing test and make sure no dot drop-out occurs. If dot drop-out is present, perform cleaning of the print heads.

- ☞ P. 51, "Printing Tests and Normal Cleaning"
- ☞ P. 66, "When Normal Cleaning Is Not Effective"

Is the print-head height appropriate?

Printing when the [HEAD HEIGHT] menu item is set to "HIGH" is coarser than when set to "LOW." Keep this set to "LOW" except when changing it is necessary, such as when you're using thick media.

- ☞ P. 101, "Adjusting the Print-Head Height to Match Media Thickness"

Have you carried out feed correction?

Large misalignment in the amount of feed of the media may result in printing that seems coarse or contains horizontal stripes. Either make the setting on the computer to match the type of media you're using, or make the setting for correction on the printer.

- ☞ P. 100, "Alleviating Horizontal Bands (feed correction function)"

Have you carried out bidirectional correction?

When you are performing bidirectional printing, use the [ADJUST BI-DIR] menu item to carry out correction. The optimal adjustment value may vary, depending mainly on the thickness of the media. Set or select an adjustment value that is suited to the media. When further correction is required, such as when adjustment made using [SIMPLE SETTING] does not enhance printing, use [DETAIL SETTING] to make correction.

- ☞ P. 99, "Correcting for Misalignment in Bidirectional Printing"
- ☞ P. 99, "Correcting for Misalignment in Bidirectional Printing More Precisely"

Is the media heating system at a suitable temperature?

If the ink forms lumps or smudges, raise the temperature. Note, however, that a temperature that is too high may degrade the media or cause it to wrinkle.

- ☞ P. 93, "Fully Utilize the Media Heating System"

Is the temperature of the room too low?

The media heating system may not warm up sufficiently when the ambient temperature is less than 20°C (68°F). Also, even when the media heating system reaches its preset temperatures, adequate effectiveness may not be apparent if the media is thoroughly chilled. Before printing, allow the media to come to room temperature.

Is the print mode suitable?

If attractive printing is impossible even when the media heating system is at a high temperature, try using a higher-quality print mode. Depending on the media, smudging may occur when using a high-quality print mode, and results may also vary greatly depending on the settings of your software RIP (such as the colorprofile selection). Make settings suited to the media you're using.

Is the printer installed in a level and stable location?

Never install the machine in a location where it is tilted or where it may wobble or experience vibration. Also make sure that the print heads are not exposed to moving air. These factors may lead to missing dots or reduced printing quality.

Is the media loaded and set up correctly?

If the media is not loaded and set up correctly, media feed may not be smooth, or printing may be adversely affected. Make sure the media is loaded and set up correctly.

☞ P. 128, "Media Feed Is Not Smooth"

Are the settings for the [PRESET] menu item appropriate?

If the settings selected with the [PRESET] menu item are not suitable for the type of media, printing may be adversely affected. Choose settings optimized to the media you're using.

☞ P. 44, "Setup of Media ([Media Setting] menu)"

☞ P. 90, "Fully Utilizing Preset Function"

Colors Are Unstable or Uneven

Did you shake the ink cartridges gently before installing them?

Shake new cartridges gently before you install them.

Is the media wrinkled?

If the media is wrinkled and comes loose from the platen, colors may be uneven or printing quality may suffer.

☞ P. 128, "Media Feed Is Not Smooth"

Was printing paused partway through?

When printing is paused, the coloring at the seam may be altered when printing resumes. Avoid pausing printing. By default, printing pauses when ink remaining inside the machine runs out. Before you perform lengthy printing, check the amount of ink remaining in the ink cartridges. Printing may also pause when data is not sent from the computer quickly enough. We recommend not performing any other tasks with the computer while printing is in progress.

Is the printer installed in a level and stable location?

Never install the machine in a location where it is tilted or where it may wobble or experience vibration. Also make sure that the print heads are not exposed to moving air. These factors may lead to missing dots or reduced printing quality.

Is the media loaded and set up correctly?

If the media is not loaded and set up correctly, media feed may not be smooth, or printing may be adversely affected. Make sure the media is loaded and set up correctly.

☞ P. 128, "Media Feed Is Not Smooth"

Are the operating parameters set to appropriate values?

Depending on the settings for such menu items as [FULL WIDTH S] and [PERIODIC CL.], uneven colors may occur. If the settings have been changed, try restoring them to their default values.

- ☞ P. 105, "Speeding Up Output for Narrow Media"
- ☞ P. 107, "Preventing Soiling of the Media and Dot Drop-out"

Are the settings for the [PRESET] menu item appropriate?

If the settings selected with the [PRESET] menu item are not suitable for the type of media, printing may be adversely affected. Choose settings optimized to the media you're using.

- ☞ P. 90, "Fully Utilizing Preset Function"

The Media Becomes Soiled When Printed

Do the print heads contact the media?

The print-head height may be too low. Also, if the media is not loaded and set up correctly, it may wrinkle or come loose and strike the print heads.

- ☞ P. 101, "Adjusting the Print-Head Height to Match Media Thickness"
- ☞ P. 127, "Media Feed is Not Smooth"

Are the print heads dirty?

The following may cause ink to drip on the media during printing.

- **Buildup of fibrous dust (lint) around the print heads.**
- **Ink transferred to the print heads due to rubbing against the media.**

If this happens, perform manual cleaning. We recommend carrying out periodic cleaning of the print heads.

- ☞ P. 69, "Maintenance that Should Be Performed More Than Once a Month"

- **Too Low Humidity.**

Use this machine in the environment of 35 to 80 %RH (non condensation).

Are the pinch rollers or the media clamps dirty?

Periodically clean them.

- ☞ P. 64, "Cleaning"

Media Jam Occurs!

The Media Jams

If an error message is displayed because the media has jammed, immediately correct the problem. Failure to do so may damage the print heads.

☞ P. 135, "[MOTOR ERROR TURN POWER OFF]"

Is the media warped or wrinkled?

Many factors can cause warping or wrinkling. Refer to the following and correct the problem.

☞ P. 128, "Media Feed Is Not Smooth"

Is the print-head height too low?

Try raising the print heads. Media may inevitably warp or wrinkle slightly, so adjust the print-head height to take this into account.

☞ P. 101, "Adjusting the Print-Head Height to Match Media Thickness"

Media Feed is Not Smooth

A variety of problems can occur if the media feed is not smooth. This can cause such problems as poor printing quality, contact with the media by the print heads, misaligned positioning, or media jams. Take action as follows.

Media Wrinkles or Shrinks

Is the media loaded and set up straight and securely?

Feed is not smooth when the media is not straight or is tensioned unevenly on the left and right. Reload the media.

☞ P. 44, "Setup of Media ([Media Setting] menu)"

Was loaded media allowed to stand for some time?

Media may shrink or wrinkle if it is heated for an extended time. When printing ends, switch off the sub power or remove the media.

Are the media clamps mounted?

When you're performing printing, be sure to attach the media clamps.

Was the media loaded while the print heater was hot?

Loading media after the print heater has warmed up causes the temperature of the media to rise suddenly, which may cause the media to shrink or wrinkle during printing. Before loading media, switch off the sub power and allow the platen to cool.

☞ P. 93, "Fully Utilize the Media Heating System"

Is the temperature of the media heating system too high?

Set the temperature to suitable values for the type of media.

☞ P. 93, "Fully Utilize the Media Heating System"

Is the temperature of room too low?

Use this machine in an environment having an ambient temperature of 20 to 32°C (68 to 90°F). If the machine is used at an ambient temperature less than 20°C, then depending on the type or width of the media, wrinkling or temperature-caused unevenness may occur. If this happens, try lowering the temperature of the media heating system by about 2°C. To obtain stable printing results, however, the machine should be used at an ambient temperature of 20 to 32°C(68 to 90°F).

Is the humidity of the room too high?

Use this machine in the environment of 35 to 80 %RH (non condensation).

Is the using media deflected?

If using the deflected media, it cause winkle of the media.

Media Feed Is Not Straight

Is the media loaded and set up straight and securely?

Feed is not smooth when the media is not straight or is tensioned unevenly on the left and right. Reload the media.

☞ P. 44, "Setup of Media ([Media Setting] menu)"

Media Feed Is Not Smooth

Do the media or the shafts strike some other object?

Make sure the media and the shafts do not touch anything else. This may affect output, even when feed appears to be smooth.

☞ P. 44, "Setup of Media ([Media Setting] menu)"

Is the media too thick?

Media that is too thick may not only cause unstable feed, but may scrape the print heads, resulting in malfunction. Never use such media.

Are the grit rollers dirty?

Check to make sure the grit rollers are free of buildup of foreign material such as media scraps.

☞ P. 64, "Cleaning"

Print Heads Stop Moving. Why?

If the print-head carriage stops over the platen, take action immediately to prevent the print heads from drying out.

What to Do First

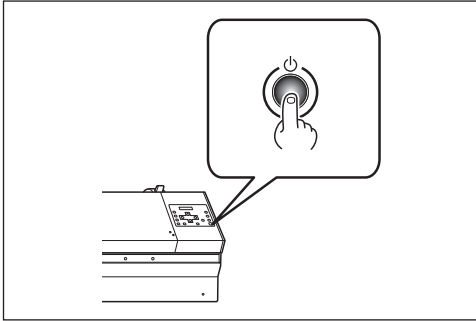

Switch the sub power off, then back on again.

If the media is jammed, then also remove the media.

If the print-head carriage move to the stand-by position (inside the cover R), it means the operation has ended successfully.

If the print heads still do not move.

Try switching off the main power, then again switching on the main power, followed by the sub power.

If the Print Heads Still Do Not Move

If the print heads still do not move, carry out the following emergency response measure, then contact your authorized Roland DG Corp. dealer.

Procedure

- 1 Switch off the main power and open the front cover.
- 2 Remove the Cover R.

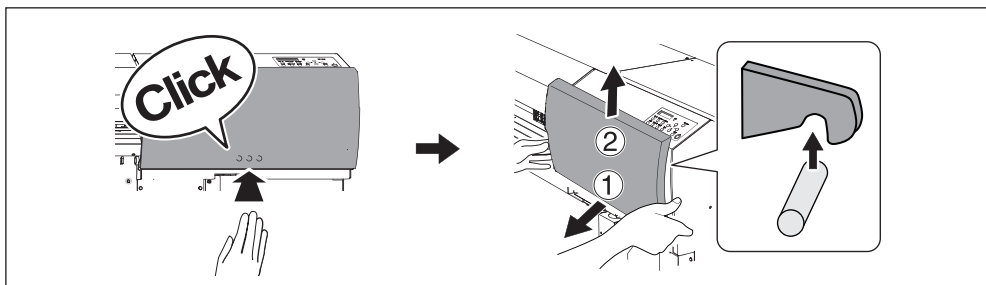

3

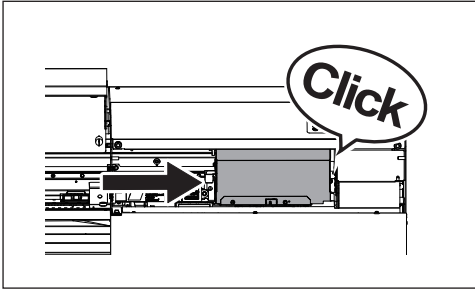

Gently move the print-head carriage to the standby position.

Stopping at the place where the audible click is heard locks the print heads in place.

4

Gently apply pressure from the right side to make sure the print heads don't move to the left.

If the print heads move to the left, again move them slowly by applying pressure from the left side and make sure they lock in place.

A Message Appears

These are the main messages that appear on the machine's display to prompt correct operation. They do not indicate any error. Follow the prompts and take action accordingly.

[1 ■ 2 ■ 3 ■ 4 ■ 5 ■ 6 ■ 7 ■ 8 ■]

Only a small amount of ink remains. Replace the cartridge indicated by the flashing number with a new cartridge.

[PRESS THE POWER KEY TO CLEAN]

This appears when the machine has been unused for about one month. Switch on the sub power once a month.

☞ P. 86, "When Not in Use for a Prolonged Period"

[CLOSE THE COVER (FRONT COVER, COVER L or COVER R)]

Close the front cover, cover L, or cover R. For safety, the carriage does not operate while a cover is open.

[SHEET NOT LOADED PRESS SETUP KEY]

Load media. This message appears when an attempt to perform a printing test was made while no media was loaded.

[END OF THE SHEET]

The trailing edge of the media was detected during operation. Press any button on the operation panel to clear the message. Load new media.

[CHECK DRAIN BOTTLE]

This appears when a certain amount of discharged fluid collects in the drain bottle. To clear the message, press **ENTER**. If this screen appears, go to the [DRAIN BOTTLE] menu and discard the discharged fluid in the bottle.

☞ P. 62, "Disposing of Discharged Ink"

[INSTALL DRAIN BOTTLE]

Check whether the drain bottle is installed. Install the drain bottle, then press **ENTER**.

☞ P. 62, "Disposing of Discharged Ink"

[NOW HEATING...]

Wait until the media heating system reaches the preset temperature. Printing starts when **HEATER** lights up. You can stop printing by holding down **SET UP** for one second or longer while this is displayed. Pressing **PAUSE** makes printing start immediately, without waiting to reach the preset temperature.

[REMOVE MEDIA CLAMPS]

This appears if **SHEET CUT** is pressed while the media clamps are attached. Remove the media clamp and press **ENTER**.

[TIME FOR MAINTENANCE]

It is time to manual cleaning manually. After verifying, press **ENTER** .

☞ P. 70, "Manual Cleaning"

[TIME FOR WIPER (FELT) REPLACE]

It is time to replace the wiper or felt wiper. After verifying, press **ENTER** .

☞ P. 78, "Replacing the Wipers"

☞ P. 81, "Replacing the Felt Wipers"

An Error Message Appears

This describes the error messages that may appear on the machine's display, and how to take action to remedy the problem. If the action described here does not correct the problem, or if an error message not described here appears, contact your authorized Roland DG Corp. dealer .

[OPTION-DRYER IS NOT CONNECTED]

When the optional dryer is not connected to the printer, [OPTION DRYER] is set to "ENABLE." Switch the sub power and main power off, and then connect the optional dryer to the printer.

[HEATING TIMEOUT CONTINUE?]

The media heating system did not reach the preset temperature.

This occurs because the temperature of the location where the machine is installed is too low. We recommend raising the temperature. To continue waiting for the temperature to rise, press **ENTER** . To start printing immediately, press **PAUSE** .

[CAN'T PRINT CROP CONTINUE?]

The size of the data including the crop marks is larger than the printing area of the loaded media.

To continue performing output without correcting this, press **ENTER** . At this time, the portion extending beyond the printing area and the crop marks are not printed. To stop output, stop sending data from the computer, then raise the loading lever. Make the printing area wider, such as by replacing the media with a larger piece of media, then send the data again.

The size of the data being output is too small.

Make the horizontal- (scan-) direction size of the data at least 65 mm (2.6 in.). To continue performing output without correcting this, press **ENTER** . At this time, the data is output without printing the crop marks. To stop output, stop sending data from the computer, then raise the loading lever. Change the size of the data, then send the data again. There is no limitation in the size of the data in the media-feed direction.

[TEMPERATURE IS TOO HIGH **°C]

The temperature of the location where the machine is installed has risen above the ambient temperature at which the machine can operate.

Operation cannot be continued. Switch off the sub power. The displayed temperature is the current ambient temperature of the installation location. Bring the installed location to a temperature at which operation is possible (15 to 32°C) and allow the machine to come to room temperature, then turn on the power.

[TEMPERATURE IS TOO LOW **°C]

The temperature of the location where the machine is installed has fallen below the ambient temperature at which the machine can operate.

Operation cannot be continued. Switch off the sub power. The displayed temperature is the current ambient temperature of the installation location. Bring the installed location to a temperature at which operation is possible (15 to 32°C) and allow the machine to come to room temperature, then turn on the power.

[SERVICE CALL xxxx]

An unrecoverable error occurred, or part replacement that must be performed by a service technician is required.

Note the number displayed, then switch off the sub power. After you switch off the power, inform your authorized Roland DG Corp. dealer of the number that appeared on the display.

[SHEET TOO SMALL CONTINUE?]

The size of the data is larger than the printing area of the loaded media.

To continue performing output without correcting this, press **ENTER**. At this time, the portion extending beyond the printing area is not output. To stop output, stop sending data from the computer, then raise the loading lever. Make the printing area wider, such as by replacing the media with a larger piece of media, then send the data again.

[SHEET SET ERROR SET AGAIN]

****SET UP** was pressed even though no media is loaded.**

Press any key to clear the error. Load media and down the loading lever, then press **SET UP**.

⇨ P. 32, "Loading Media"

[SHEET TYPE] is set to "OPAQUE," but transparent media was loaded.

Raise the loading lever, set the [SHEET TYPE] menu item to "CLEAR," then reload the media.

⇨ P. 102, "Using Transparent Media"

The loaded media is too small.

Press any key to clear the error. Replace with media of usable size.

[DATA ERROR CANCELING...]

Output was stopped because a problem was found in the data received.

Operation cannot be continued. Check for a problem with the connector cable or the computer, and redo the operation from the step of loading the media.

[PINCHROLL ERROR LOWER PINCHROLL]

****SET UP** was pressed without first lowering the pinch rollers.**

Press any key to clear the error. Down the loading lever, then press **SET UP**.

The pinch rollers were raised while **SET UP was illuminated.**

The error is cleared automatically after a short wait. Never move the loading lever while printing is in progress.

[WRONG CARTRIDGE]

A cartridge that cannot be used was installed.

Remove the cartridge to clear the error. Use a cartridge of the specified type.

[CLEANING ERROR]

The printer made an emergency stop because an ink cartridge was removed while light choke cleaning or ink filling for the first time in the printer was in progress.

The ongoing task cannot be continued. Switch the sub power off by holding down the switch for one second or longer, and then back on. Then perform the [INK RENEWAL] menu. After the [INK RENEWAL] menu is finished, perform light choke cleaning or ink filling from the beginning.

⇨ P. 76, "When Problems Such As Dot Drop-out are Not Cleared Up"

[CANCELED FOR PUMP PROTECTION]

The printer made an emergency stop because the following state has continued for 10 minutes or longer while light choke cleaning or ink filling for the first time in the printer was in progress.

- Printer is left with an ink cartridge removed.
- Printer runs out of ink.

The ongoing task cannot be continued. Switch off the sub power. After switching off the power, contact your authorized Roland DG Corp. dealer.

[AVOIDING DRY-UP TURN POWER OFF]

The print heads were forced to standby position to prevent them from drying out.

Operation cannot be continued. Switch the sub power off, then back on.

[SET HEAD HEIGHT TO xxx]

The print-head height is lower than the height specified on the software RIP.

This warning indicates that the print-head height is too low for the media thickness specified on the software RIP. The print heads move to a location where you can operate the height-adjustment lever. Adjust to the displayed height, then press **ENTER**.

☞ P. 101, "Adjusting the Print-Head Height to Match Media Thickness"

[MOTOR ERROR TURN POWER OFF]

A motor error occurred.

Operation cannot be continued. Switch off the sub power. Next, eliminate the cause of the error, then immediately switch on the sub power. If the machine is allowed to stand with the error uncorrected, the print heads may dry out and become damaged. This error may be caused by such factors as a mistake in loading the media, a media jam, or an operation that pulls the media with excessive force.

The media has jammed.

Carefully remove the jammed media. The print heads may also be damaged. Perform cleaning of the print heads, then perform a printing test and check the results.

The media was pulled with excessive force.

Excessive tension was applied to the media, and additional action is necessary to recover from this state. First, down the loading lever and adjust the media to create a small amount of slack, then switch on the sub power.

[WRONG HEAD IS INSTALLED]

Unusable print heads are installed.

Switch off the sub power. After you switch off the power, inform your authorized Roland DG Corp. dealer.

[CANCELED FOR MOTOR PROTECTION]

Either of the following menu items is to be started in a row within 10 minutes:

- Ink filling when purchasing this machine
- PUMP UP
- HEAD WASH

Press any key other than the sub power switch to cancel the error message. Allow the machine to stand for approximately 10 minutes before resuming operation. These menu items require the pump motor to turn for a long time. When performing these menu items in a row, take an interval of at least 10 minutes to prevent damage to the machine due to the overheating of pump motor.

Chapter 7

Main Specifications

Printing Area	138
Maximum Area and Margins.....	138
Maximum Area When Using Crop Marks	139
The Media-cutoff Location During Continuous Printing	139
Locations of the Power Rating and Serial Number Labels	140
Specifications.....	141

Printing Area

Maximum Area and Margins

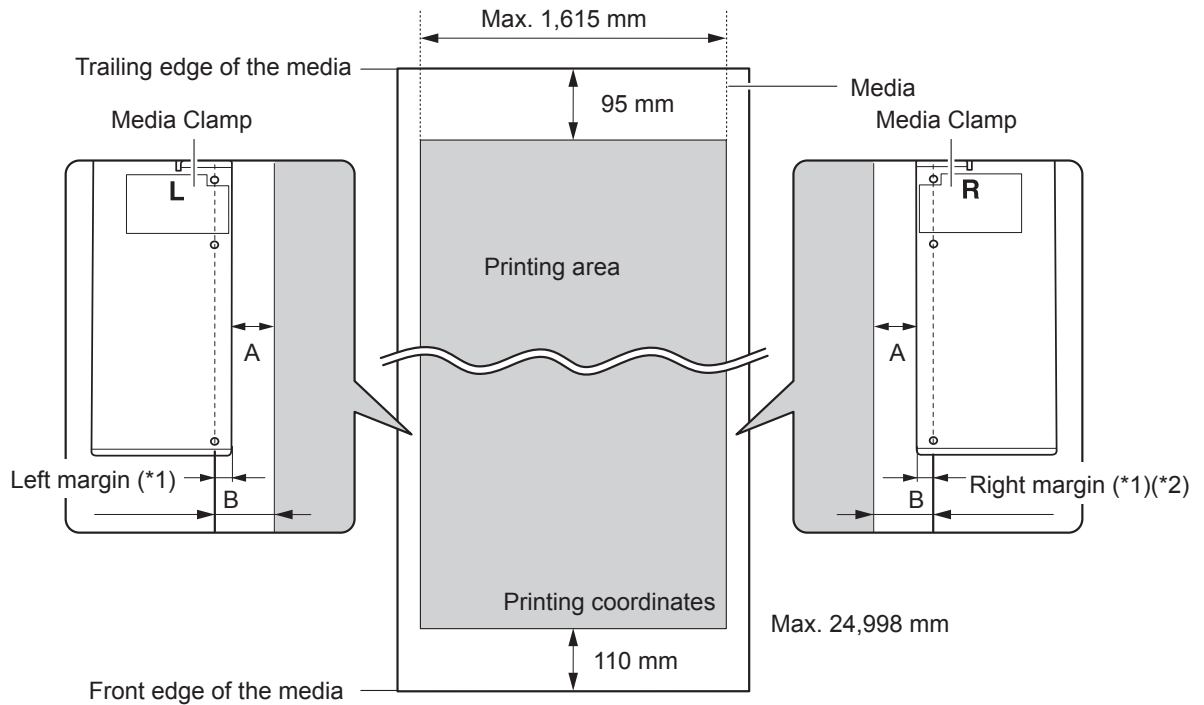

A: Setting of the [SIDE MARGIN] menu item (5 mm, 10 mm (default setting), or 25 mm)
B: Width clamped by the media clamp (approx. 5 mm)

*1 The amount of the left and right margins is the total of A and B. In the following cases, however, the setting for A becomes the amount of margin without change.

- When media has been loaded without installing the media clamps
- When the [SHEET TYPE] menu item is set to [CLEAR] (regardless of whether the media clamps are present)

*2 The amount of right margin can be changed by making the setting of base point (print-start position).

☞ P. 50, "Setting the Output-start Location"

Maximum Area When Using Crop Marks

When crop marks are used, the printing area is reduced from the maximum area by an amount equal to the crop marks.

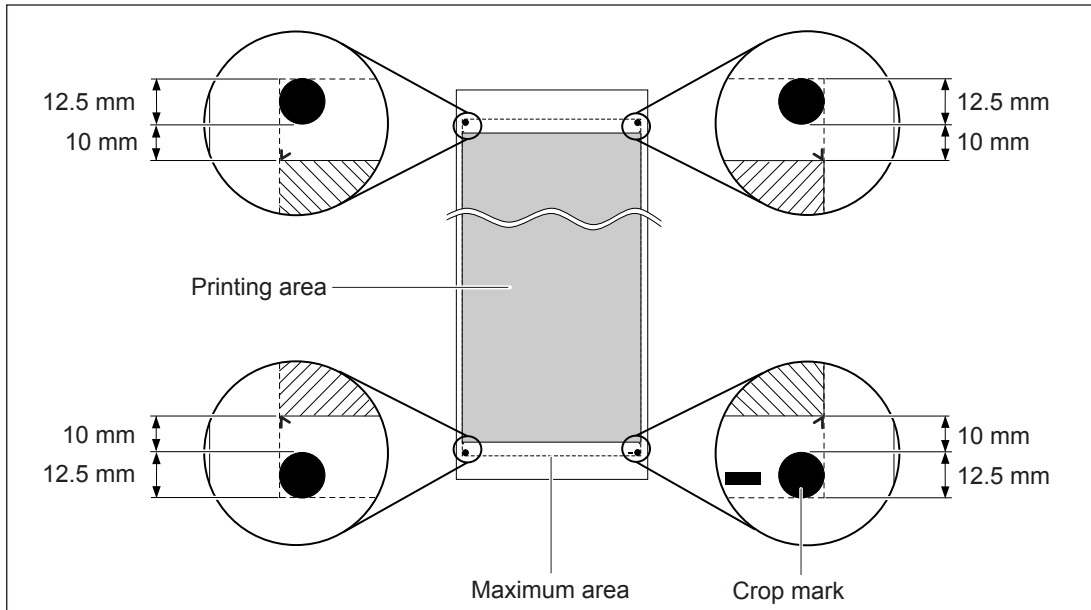

The Media-cutoff Location During Continuous Printing

When a media-cutoff command is sent from the computer, the cutoff location on the media is as shown in the figure below.

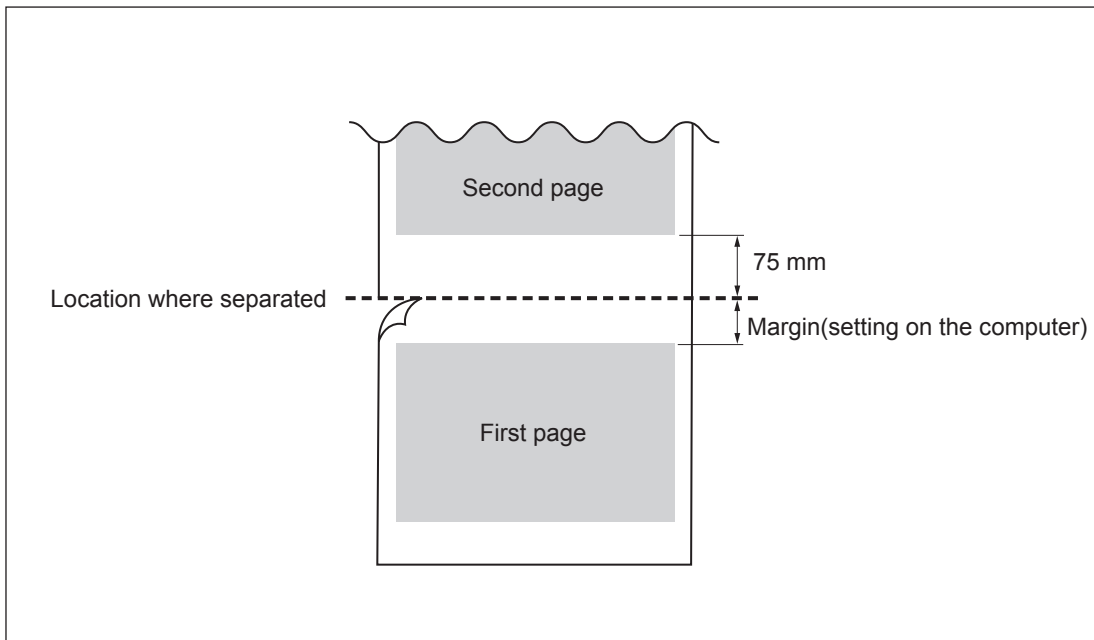

Locations of the Power Rating and Serial Number Labels

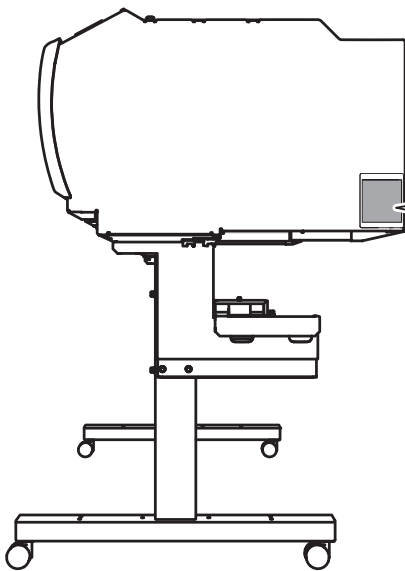

Serial Number

This is required when you seek maintenance, servicing, or support. Never peel off the label or let it get dirty.

Power Rating

Use an electrical outlet that meets the requirements for voltage, frequency, and amperage given here.

Specifications

		XF-640
Printing technology		Piezoelectric inkjet
Media	Width	259 to 1,625 mm (10.2 to 64 in.)
	Thickness	Maximum 1.0 mm (39 mil) with liner
	Roll outer diameter	Maximum 210 mm (8.3 in.)
	Roll weight	Max. 40 kg (88 lb.)
	Core diameter (*1)	76.2 mm (3 in.) or 50.8 mm (2 in.)
Printing width (*2)		Max. 1,615 mm (63.6 in.)
Ink cartridges	Types	440-cc cartridge
	Colors	Cyan, Magenta, Yellow, Black
Printing resolution (dots per inch)		Maximum 1,440 dpi
Distance accuracy (*3)		Error of less than ± 0.3 % of distance traveled, or ± 0.3 mm, whichever is greater
Media heating system(*4)		Print heater and preheater, setting range for the preset temperature: 30 to 45°C (86 to 112°F) Dryer, setting range for the preset temperature: 30 to 55°C (86 to 131°F)
Connectivity		Ethernet (10BASE-T/100BASE-TX, automatic switching)
Power-saving function		Automatic sleep feature
Power requirements		AC 100 to 120V $\pm 10\%$, 11 A, 50/60 Hz or AC 220 to 240V $\pm 10\%$, 6 A, 50/60 Hz
Power	During operation	Approx. 1350W
	Sleep mode	Approx. 20 W
Acoustic noise level	During operation	62 dB (A) or less
	During standby	45 dB (A) or less
Dimensions (with stand)		2,750(W) x 800(D) x 1,295 (H) mm (108 (W) x 31 (D) x 50 (H) in.)
Weight (with stand)		177 kg (390 lb.)
Environmental	Power on (*5)	Temperature: 15 to 32°C (59 to 90°F) (20°C [68°F] or more recommended), humidity: 35 to 80%RH (non-condensing)
	Power off	Temperature: 5 to 40°C (41 to 104°F), humidity: 20 to 80%RH (non-condensing)
Accessories		Exclusive stands, power cord, media clamps, media holder, replacement blade for separating knife, software RIP, User's Manual, etc.

*1

The media holder of this machine is exclusive use for the media of paper tube (core) inner diameter 3 inches. To use 2 inches media, the optional media flanges are required.

*2

The length of printing is subject to the limitations of the program.

*3

- Media type: Media specified by Roland DG Corp.
- Temperature: 25°C (77°F), humidity: 50%
- Roll media must be loaded correctly.
- Excluding expansion/contraction of the media
- Not assured when the pre-heater, print heater or dryer is used.
- All correction or adjustment function of this machine has been made properly.
- Print travel: 1 m

*4

- Warm-up is required after power up. This may require 5 to 20 minutes, depending on the operating environment.
- Depending on the ambient temperature and media width, the preset temperature may fail to be reached.

Specifications

*5

➤ Operating environment

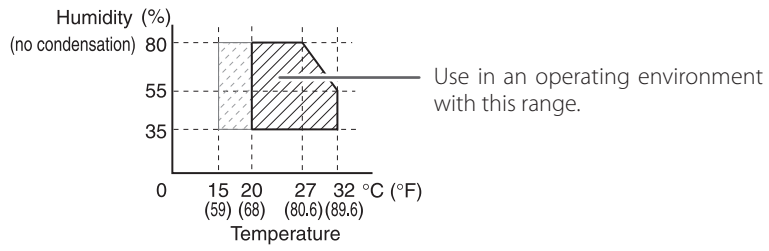

For China

产品中有毒有害物质或元素的名称及含量

部件名称	有毒有害物质或元素					
	铅(Pb)	汞(Hg)	镉(Cd)	六价铬 (Cr(VI))	多溴联苯 (PBB)	多溴二苯醚 (PBDE)
印刷电路板	×	○	×	○	○	○
头部	×	○	○	○	○	○
壳体、底架	×	○	○	○	○	○
电源	×	○	×	○	○	○
其他(电缆、附件等)	×	○	○	○	○	○

○：表示该有毒有害物质在该部件所有均质材料中的含量均在 GB/T26572-2011 标准规定的限量要求以下。

×：表示该有毒有害物质至少在该部件的某一均质材料中的含量超出 GB/T26572-2011 标准规定的限量要求。

环保使用期限



此标志适用于在中国国内销售的电子信息产品，表示环保使用期限的年数。所谓环保使用期限是指在自制造日起的规定期限内，产品中所含的有害物质不致引起环境污染，不会对人身、财产造成严重的不良影响。环保使用期限仅在遵照产品使用说明书，正确使用产品的条件下才有效。不当的使用，将会导致有害物质泄漏的危险。

For EU Countries



This product must be disposed of separately at your local waste recycling center. Do not dispose of in household waste bin.



Lever dit product in bij een lokaal afvalverzamelpunt. NIET met normaal huishoudelijk afval afvoeren.



Bitte führen Sie dieses Produkt separat Ihrer örtlichen Entsorgungsstelle zu. Bitte nicht mit dem normalen Hausmüll entsorgen.



Dette Produkt skal smides særskilt væk på den lokale affalds- og genbrugsstation. Må ikke smides ud sammen med almindeligt husholdningsaffald.



Ne jetez pas le produit avec vos ordures ménagères. Portez-le dans un centre recyclage des déchets.



Tätä tuotetta ei saa hävittää normaalien talousjätteiden mukana, vaan se on toimitettava ongelmajätteiden keräily pisteeseen hävitettäväksi.



Questo prodotto deve essere smaltito negli appositi contenitori per la raccolta differenziata, non buttare nel cestino dei rifiuti casalinghi.



Produkten måste kasseras separat på din lokala återvinningscentral. Släng inte produkten tillsammans med hushållssoporna.



Este producto debe devolverse al centro de reciclaje más cercano a su domicilio para su correcta eliminación. No lo tire a la basura.



Μην πετάξετε το αντικείμενο αυτό στο καλάθι των απορριμμάτων. Αφαιρέστε τις μπαταρίες και προσκομίστε το στο τοπικό κέντρο ανακύκλωσης.



Deite fora separadamente este produto no seu centro de reciclagem local. Não o deite fora no seu caixote do lixo.

 **Roland**



R1-130121